



## MATEST AND PAVETEST, THE BEST SYNERGY IN ROAD PAVEMENTS

---

**Performance and dynamic tests on bituminous mixtures** are crucial in road pavement engineering. They make it possible to simulate situations of load and vehicular traffic on the road surface, acquire the material's physical and mechanical response and predict the performance and durability of the pavement itself already at the design stage.

On the strength of its forty-year experience, **Matest set-up in 2012 its division Pavetest**, specialising in this strategic sector. Pavetest is a brand with a strong focus on pavement engineering, created by aggregating the best skills available at the international level and developing, thanks to these skills, a range of highly innovative products, oriented to the new performance requirements of the most advanced road and research laboratories.

Many supplies and references include the world's best universities, research centres, road construction companies, and commercial laboratories. With a wide and modular range, **Pavetest is able to offer technological solutions whatever the needs of a laboratory, from standard to sophisticated or customised tests.**

# HEAD OFFICE & MANUFACTURING PLANT



40

Years of  
experience



12.000

Square metres  
facility



1

Australian  
branch

Via delle Industrie 25  
Treviolo, Bergamo, Italy



**MATEST**<sup>®</sup>  
INNOVATIVE. GLOBAL. MANUFACTURER.

**PAYETEST**<sup>®</sup>  
WHERE TECHNOLOGY MEETS THE PAVEMENT.



**REALITY**

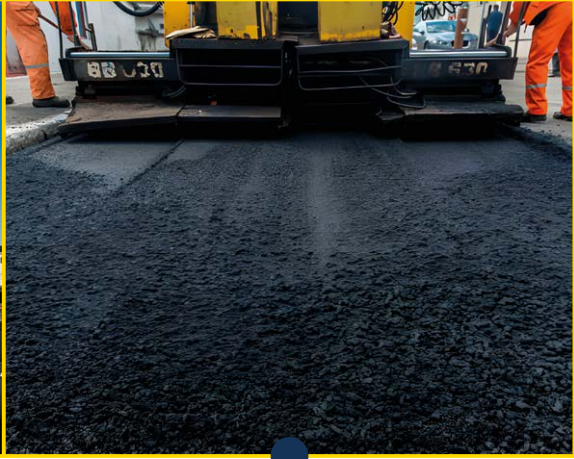

**PLANT MIXING**

**LAYING**



**AGGREGATES**



**BITUMINOUS BINDER**

**LAB MIXING**

**COMPACTION / MODELLING**

**LABORATORY**





COMPACTION



LOADING



STRUCTURAL RESPONSE

The **bituminous mixture**, consisting of bitumen, aggregates, and filler, forms a durable road surface crucial for **vehicle transit** and **safety**. Quality components, proper mixing, and precise laying and compaction techniques are essential for **optimal performance**. Building a **quality road** is challenging but cost-effective, reducing **maintenance expenses** and **extending lifespan**. Matching design parameters to on-site conditions is critical for durability. A well-constructed road enhances **safety** for passing vehicles, making investment in proper construction **worthwhile**.

**Laboratory testing** is vital for road designers, aiding in quality assessment of bituminous mixture components. **Testing machines** accurately gauge suitability, create **representative test specimens** that must replicate the **on-site condition**, and analyse mechanical properties under different conditions like workloads and stress representing road and traffic real cases. **Matest offers a comprehensive range of testing machines** compliant with international standards, ensuring durability and reliability in assessing road construction materials.



TEST



**B026-05N****PaveMix****Automatic Asphalt Large Laboratory Mixer, 32 litres capacity**

STANDARD: EN 12697-35 | ASTM D6307 | AASHTO TP53

The PaveMix has been expressly designed to prepare homogeneous bituminous mixtures at a strictly controlled temperature. The preparation of the bituminous mixture is obtained in a short time period (few minutes) to avoid any mechanical aggregate degradation and to fully coat all mineral components, as requested by EN 12697-35. The helical mixing blades are detachable to facilitate the cleaning procedure.

**MAIN FEATURES**

- Mixing capacity: 32 litres max.
- Mixing bowl: stainless steel AISI 316.
- Slot on the top of the lid to pour filler and additives during mixing.
- Mixing temperature: selectable from ambient up to 260 °C through sensitive probe and digital display control.
- Mixing speed: adjustable from 4 to 40 rpm.
- Easy tilting unloading operation by electromechanical motion with rotation up to 130°.
- Strictly controlled temperature.
- Fast preparation of bituminous samples.
- Detachable mixing blades to facilitate the cleaning and maintenance procedure.

**B026-05N**

### The Pavemix produces bituminous mixtures to perform:

- Gyrotory compaction tests (EN 12697-10, EN 12697-31)
- Marshall stability tests (EN 12697-34, EN 13108)
- Wheel tracking wet and dry tests (EN 12697-22)
- Slabs compaction laboratory tests (EN 12697-33)
- Beam fatigue and Stiffness tests (EN 12697-26, EN 13108)
- Asphalt general purpose tests.

### PaveMix consists of:

- Main frame holding a horizontal stainless steel bowl with a helical mixing shaft.
- The bowl, double wall insulation made of stainless steel AISI 316, contains an electric heater with probe sensor granting constant and uniform temperature control.
- **An electromechanical motion allows to tilt the bowl facilitate the unloading operation, with total rotation up to 130°.**

### The control panel foresees:

- Digital thermo regulator to set temperature and to control the mixing temperature.
- Mixing speed regulator.
- Main and start/stop switches.
- Rotation inversion of the blades.
- Command to tilt the bowl.

**Heating power:** 3000W

**Power supply:** 230V 1ph 50-60Hz 4500W

**Dimensions:** 1280x700x1210 mm

**Weight:** 350 kg approx.

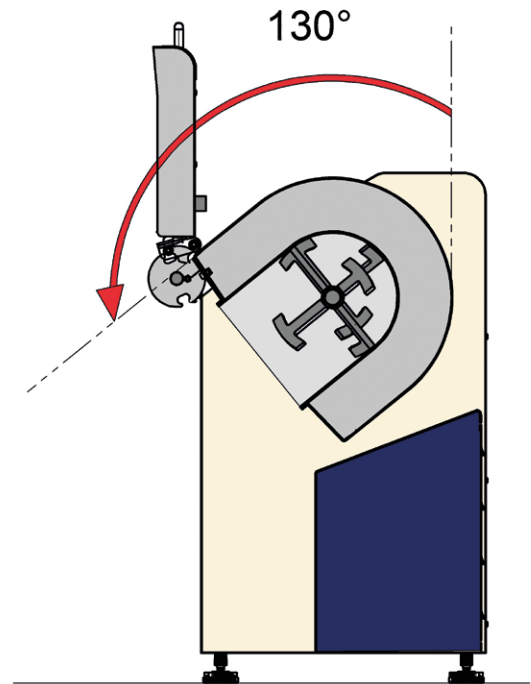

Unloading procedure.

Easy tilting of the bowl by electric motion with rotation angle up to 130°

## ACCESSORY

### B026-10N COLLECTING PAN



**B026-10N**



Detail of the detachable mixing shaft with helical blades



Detail: slot on the top of the lid



## GYRATORY COMPACTORS

STANDARDS: EN 12697-10, EN 12697-31 | ASTM D6925 | AASHTO T312, TP4 | SHRP M 002 | AS/NZS 2891 | NT BUILD 427

These gyratory compactors, which are entirely developed and manufactured by Matest, have multiples uses both for concrete and asphalt fields. They are used:

- To simulate and reproduce real compaction condition and actual road paving to determine the compaction properties of asphalt in compliance with ASTM, EN and AS Standards.
  - To simulate and reproduce kneading action of concrete mixes and compaction in precast production lines according to NT build 427.
- Electro-pneumatic or electro-mechanical, we provide several models, including for research purposes.



**B041M**



**B045**



**B045-01**

### MAIN FEATURES

- Rigid steel frame ensuring excellent angle control.
- Full color 7" touch screen control unit, running like a standard PC.
- Software for PC control data acquisition and processing.
- Electronic angle positioning.
- Dual angle option with double calibration AASHTO, EN and AS at 2 and 3.
- Automatic adjustment of the gyratory angle is defined by the user (GYRORESEARCH).
- Shear stress measurement (GYRORESEARCH).
- Optional integrated electromechanical extruder.
- Optional integrated balance.

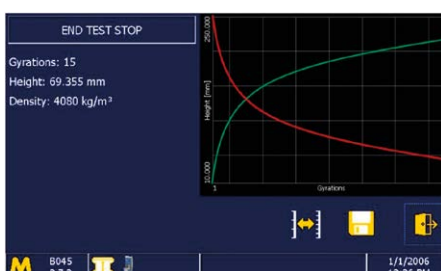

End test data (with shear stress value)

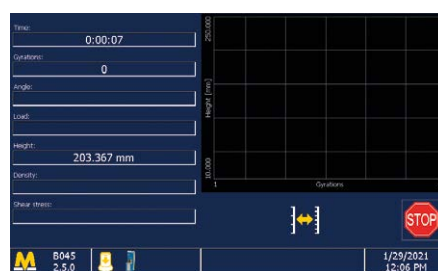

Test execution (data pilot)

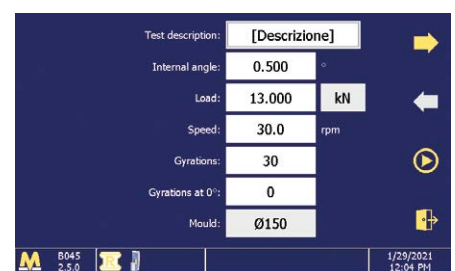

Setting of test parameters

## TECHNICAL SPECIFICATIONS

- Compacted specimen size: Ø 100 and 150 mm; height from 0 to 200 mm for both sizes.
- Mould dimensions: Internal Ø 100 and 150 mm; height 250 mm for both moulds.
- Gyrotory angle: adjustable from 0 to 2.4° (up to 3°)
- Number of cycles (gyrotory): adjustable from 1 to 5000
- Gyration rate: adjustable from 5 to 60 work cycles/min (30 cycles/min requested by Standards)
- Applied pressure on Ø 150 mm specimen: adjustable from 10 to 1000 kPa (1000 kPa with 10 bar compressor) (800 kPa with 8 bar compressor) (700 kPa with 7 bar compressor)
- Applied pressure on Ø 100 mm specimen: adjustable from 23 to 1500 kPa (with 7 bar compressor)
- The vertical pressure on the specimen is automatically controlled and adjusted by the electronic system.

### For electromechanical models

#### Applied pressure

Up to 1000 kPa for Ø 150 mm specimen

Up to 2300 kPa for Ø 100 mm specimen

Modes of operation:

- Compaction of specimen in accordance to the selected number of rotations.
- Compaction of specimen upon reaching the selected height.
- Compaction of specimen upon reaching the selected density.
- **The machine can also perform a final flatterring cycle at “zero” angle to obtain specimens with perpendicular faces.**

Data acquisition: number of rotations, specimen height, applied load (to ensure tolerances requested by the Standards)

Requires pressurized air, minimum 7 bar.

The Matest Gyrotory Compactor is **supplied complete** with lubricant and power cord.

**Optional extra are:** moulds, filter paper, penetration pistons, extruder, bench, air compressor Accredia official vertical load calibration certificate, to be ordered separately (see accessories)

**Power supply:** 230V 1ph 50-60Hz 1000W 12A

Overview of mechanical “heart”

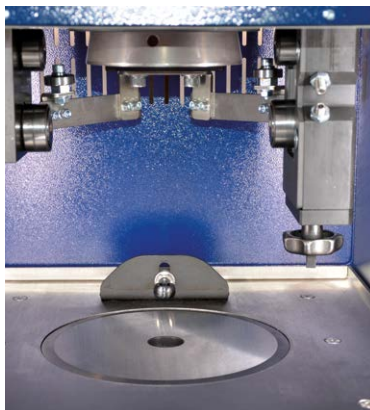

Compaction phase: simultaneous action of a static compression and of the shearing action



Dimensions and weight	B041M	B045	B045-01
With worktop	640x860x2140 mm 350 kg	640x860x2140 mm 370 kg	700x900x2200 mm 380 kg
Without worktop	640x510x1400 mm 260 kg	640x505x1420 mm 280 kg	700x560x1450 mm 300 kg

## PNEUMATIC MODELS

Gyrotronic compacts in a fully automatic way, by combining the rotary action and the vertical resultant force applied by a mechanical head. Gyrotronic is equipped with a high performance, value engineered, electropneumatic loading system. **Load is applied by an electro-pneumatic cylinder, servo controlled by a precision pressure regulator;** the height is measured by a linear transducer.

**The machine is calibrated at Matest factory to the selected internal angle.** This concept provides a simple, cost-effective solution with reduced maintenance requirement.

### B041M GYROTRONIC - ASTM

STANDARDS: ASTM D6925 | AASHTO T312 | SHRP M-002  
The machine is calibrated at Matest factory and supplied with the internal angle set to 1.16° as requested by ASTM, AASHTO Specifications.

### B041M EN GYROTRONIC - EN

STANDARDS: EN 12697-10, EN 12697-31  
The machine is calibrated at Matest factory and supplied with the internal angle set to 0.82° as requested by EN Specifications.

ACCESSORIES: See next pages

## ELECTROMECHANICAL MODELS

A complete electromechanical system where compressed air is not required.

Electromechanical gyratory motion and vertical load for a complete and precise control of compaction and specimen extraction. The machine can also perform **automatic final fluttering cycles at zero angle** to obtain specimens with perpendicular faces.

### B045 GYROMECC - ASTM

Electromechanical gyratory compactor. The load is applied by an electro-mechanical cylinder with a load cell positioned directly on the vertical actuator for precise load measurement.

### B045 EN GYROMECC - EN

Same as B045 but in compliance with EN Standards.

### B045-01 GYRORESEARCH

Used for research purposes, this electromechanical compactor allows for the **adjustment of the gyratory angle, selectable in a range between 0° and 3°**, during compaction, real time direct shear and torque measurement.

## ACCESSORIES to perform the test: (for all Gyrotronic models)

- B041-05** HARDENED SPECIMEN CYLINDER Ø 100 mm complete with bottom plate
- B041-06** HARDENED SPECIMEN CYLINDER Ø 150 mm complete with bottom plate
- B041-08** HARDENED SPECIMEN CYLINDER Ø 100 mm with holes for cold mix compaction, complete with bottom plate
- B041-09** HARDENED SPECIMEN CYLINDER Ø 150 mm with holes for cold mix compaction, complete with bottom plate
- B041-11** TOP PENETRATION PISTON Ø 100 mm
- B041-12** TOP PENETRATION PISTON Ø 150 mm

Metallic discs, to make easier the handling of specimens after the test, strongly recommended accessory for low-cohesion mixtures, such as draining asphalts:

- B041-13** METALLIC DISC for Ø 100 mm moulds. Pack of 2
- B041-14** METALLIC DISC for Ø 150 mm moulds. Pack of 2

Hollow Punches for Gyratory Compactor:

Used to maintain the core in the right shape and store cohesive asphalt samples after compaction.

Some asphalt mixes can be very unstable due to their high void ratio and large particle size. Wrapping the sample around the hollow punch will prevent it from crumbling down or receiving physical deformations once it is ejected from the mould.

The material will then settle down and assume its stiff properties once it cools down after compaction:

#### B041-17

HOLLOW PUNCH to stabilize and to mature the sample Ø 100 mm

#### B041-18

HOLLOW PUNCH to stabilize and to mature the sample Ø 150 mm

Paper discs, to prevent asphalt from sticking to the piston and the mould's base plate, and to absorb bitumen in excess:

**B041-15** FILTER PAPER for Ø 100 mm moulds. Pack of 100

**B041-16** FILTER PAPER for Ø 150 mm moulds. Pack of 100



## RECOMMENDED ACCESSORIES

- B041-20** WORKTOP FOR B041M, B041M-EN, B045 and B045-EN, it can also house the specimen extruder (B041-23 and B045-23) and the integrated balance (B041-26)
- B041-19** WORKTOP FOR B045-01, it can also house electromechanical specimen extruder (B045-23) and the integrated balance (B041-26).



## ACCESSORIES

- B041-23** PNEUMATIC AUTOMATIC SPECIMEN EXTRUDER, it can be fixed to the worktop B041-19, B041-20, or to any bench.
- B045-23** ELECTROMECHANICAL AUTOMATIC SPECIMEN EXTRUDER, it can be fixed to the worktop B041-19 and B045-20.
- V207** AIR COMPRESSOR, pressure 10 bar.  
Technical details: see General Catalogue
- B041-35** FILTER GROUP for condensed water removal from the compressed air. (needed accessory).
- B041-21** WHEELS (kit of 4) with brake, for an easy displacement of the Compactor in the laboratory.
- B041-30** VERTICAL FORCE TESTING DEVICE with load ring.  
As alternative:
- B041-31** VERTICAL FORCE TESTING DEVICE with digital dynamometer.
- B041-33** KIT OF 2 DISTANCE PIECES of 105 and 115 mm high for the control of the height values measured by the linear transducer.
- S337-52** ACCREDIA official vertical load calibration certificate.

## WEIGHING SOLUTIONS

**B041-26**  
**BALANCE, integrated** into the worktop, to facilitate the sample and the mould weightings, by avoiding the stress of lifting them.

The weighing reading values are directly and automatically displayed on the control panel of the Compactor.

Capacity: 30 kg

Accuracy:  $\pm 6$  g



OR **B041-27**  
**BENCH** for lateral bearing of a weighing balance.

Suggested balance:

V075-13 Capacity 30 kg div. 0.5 g

Or customer's own balance



**B039N**
**ARC**
**ASPHALT ROLLER COMPACTOR**

ADVANCED ELECTROMECHANICAL SYSTEM,  
 HIGH LOAD, HOT ROLL, MULTI SIZE

STANDARDS: EN 12697-33 method 5.2 and EN 12697-33 annex A  
 ASTM D8079

Asphalt Roller Compactor is entirely developed and manufactured by Matest. The machine works with an electromechanical system, and therefore it does not require any air source (compressor) or hydraulic pressure. It is used to produce representative sample slabs of several dimensions of bituminous mixtures laid and compacted on site. The compaction is performed through a segmented roller with alternated operated rotation which simulates the on-site action of a street roller. Three transducers are installed to manage the roller and table displacements and vertical load pressure.

These samples are compatible for rut test with Matest Smartracker B038AM (see p. 18). The sample slabs can be also cored or cut off to obtain cylinders and beams for bending fatigue, indirect tensile, static and dynamic creep, stiffness, and 4-point tests.



**B039N**  
 with open guard

**MAIN FEATURES**

- **40 kN vertical force.**
- Sturdy frame made of steel.
- Alternating displacement system, for table displacement and vertical load pressure.
- Integrated touch screen control unit.
- Easy management and analysis of data, test results, graphs.
- Touch-screen icon for an easy parameters set up and an immediate test execution.
- Unlimited memory storage with: 2 USB ports, 1 SD card slot.
- Direct Internet and Intranet (LAN) connection for remote technical assistance and for software updates (see General Catalogue).
- **Heating of the segment roller (optional).**
- Simple and quick roller and mould positioning.
- Perfect horizontal flatness of the slab surface.
- Uniform density and dimensions of the slabs.
- Energy controlled compaction procedure.
- Silent compaction.

**TECHNICAL SPECIFICATIONS**

- Possibility to use **standard or heated segment rollers of different sizes** (see accessories): width up to 400 mm, length up to 500 mm and radius 490 mm, to obtain slabs of
  - 500x400 mm, thick up to 180 mm
  - 400x305x25 to 100 mm thick
  - 320 x260 mm, thick up to 180 mm
  - 305x305x25 to 100 mm thick
- Vertical force selectable up to max. 40 kN (for all machine)
- **Programmable density target compaction**
- Polycarbonate safety guard as requested by CE Directive
- Possibility to **perform the two-phase procedure (Pre-compaction and Compaction)** as specified by TP Asphalt-StB 33 and EN 12697-33 annex A
- Possibility to set and control the test by n° passes
- **Sliding carriage speed adjustable** between 3 m/min and 12 m/min
- **Detailed output file** listing each pass and displaying duration, sample height, applied load and eventual roller and cart temperature
- Longitudinal compaction
- **Power supply:** 230 V 50-60 Hz 1ph 2100 W  
 (3100W with the heated segment roller)
- **Dimensions:** 2200x1030x1880 mm  
 (2410 mm with opened guard)
- **Weight:** 1300 kg approx.

## ACCESSORIES

**STANDARD SEGMENT ROLLER**, available models:

Code	Mould dimensions
<b>B039-04</b>	320x260 mm
<b>B039-05</b>	500x400 mm
<b>B039-06N</b>	400x305 mm
<b>B039-07</b>	305x305 mm

**STANDARD CENTERING PLATE**, available models:

Code	Mould dimensions
<b>B039-21N</b>	400x305 mm
<b>B039-22</b>	305x305 mm
<b>B039-23</b>	320x260 mm
<b>B039-24</b>	300x300 mm

**B039-15** ROLLING VIBRATING DEVICE, reproducing street-roller vibrations during asphalt laying off.

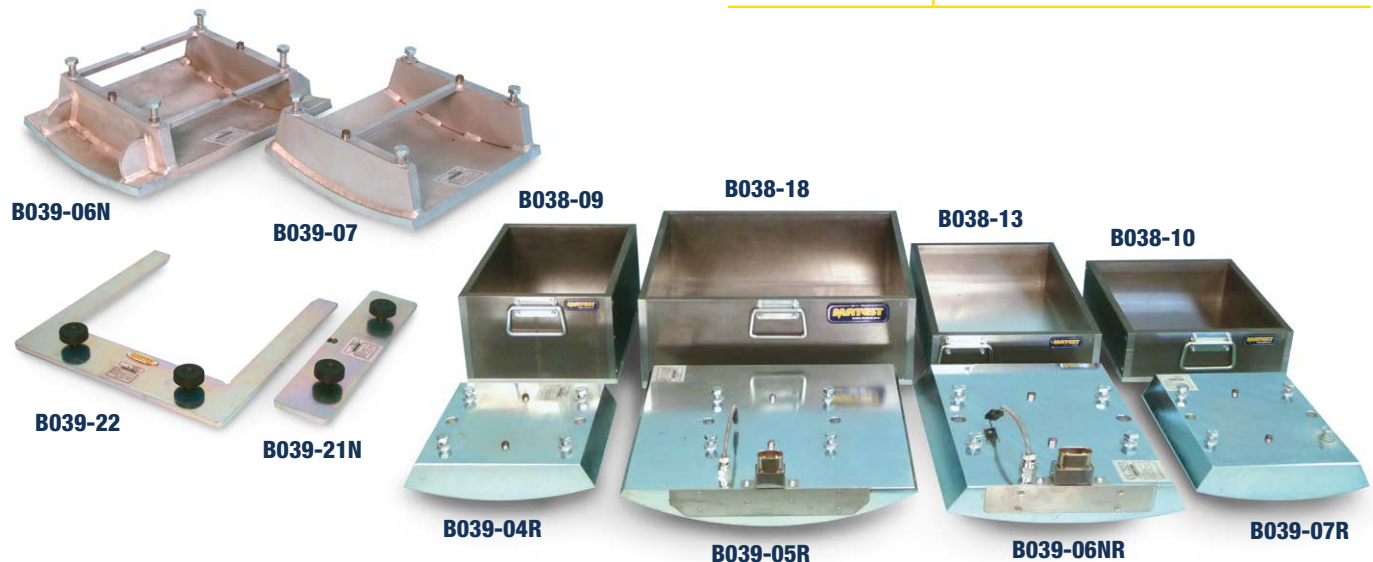

**MOULD** to prepare asphalt slabs. Complete with handles.

Code	Dimensions
<b>B038-09</b>	320x260x180 mm
<b>B038-10</b>	305x305x50 mm
<b>B038-11H</b>	305x305x120 mm
<b>B038-12</b>	400x305x50 mm
<b>B038-13</b>	400x305x100 mm
<b>B038-15</b>	400x305x180 mm
<b>B038-18</b>	500x400x180 mm
<b>B038-19</b>	400x305x120 mm
<b>B038-20</b>	320x260x50 mm
<b>B038-21</b>	500x305x120 mm
<b>B038-22</b>	300x300x120 mm
<b>B038-23</b>	320x260x100 mm
<b>B038-24</b>	400x500x100 mm

## Heating of Segment Roller and Sliding Cart

Possibility to heat and control temperature of the Segment Roller mounted on the Compactor and Sliding Carriage to keep the mould warm and avoid thermal shocks the might affect specimen's workability.

The equipment is composed of:

### B039-02 CONTROL UNIT

Mounted in the Roller Compactor, it foresees a thermoregulator circuit, complete with probe to measure and to adjust the temperature from room up to 180 °C.

It is connected to the segment roller equipped with heating resistances, to be connected to the control unit B039-02.

**HEATED SEGMENT ROLLER**, complete with heating resistances.

Available dimensions:

<b>B039-04R</b>	ROLLER for 320x260 mm mould
<b>B039-05R</b>	ROLLER for 500x400 mm mould
<b>B039-06NR</b>	ROLLER for 400x305 mm mould
<b>B039-07R</b>	ROLLER for 305x305 mm mould
<b>B039-08R</b>	ROLLER for 505x305 mm mould
<b>B039-09R</b>	ROLLER for 300x300 mm mould

### B039-03 SLIDING CART HEATING OPTION

Thermoregulated circuit with temperature probe to set and control cart temperature and keep mould hot. The temperature is adjustable from ambient up to 140 °C.

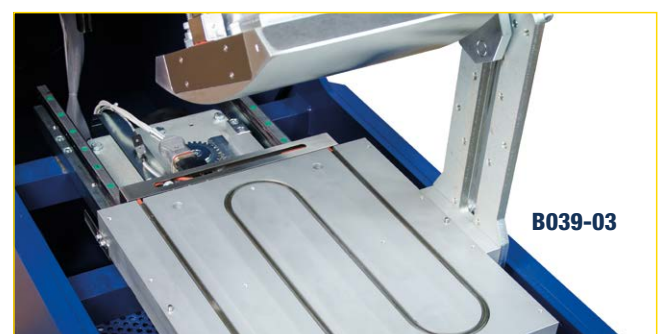

**B039A**
**ASC**
**ASPHALT SHEAR BOX COMPACTOR**

THE ONLY ELECTROMECHANICAL SHEAR BOX COMPACTOR

**STANDARD: ASTM D7981-15** Standard practice for compaction of prismatic asphalt specimens by means of the Shear Box Compactor.

 The ASC is being **used in FHWA Contract** "Deployment of Performance-Based Technologies for Mechanistic-Empirical Pavement Design and Resource Responsible Materials Design" to produce specimens for Level 1 analyses using the AASHTOWare Pavement ME Design software.

It is the only compactor capable of creating specimens for all of the following mechanistic-empirical performance tests:

**Dynamic Modulus**, AASHTO PP 61

**Repeated Load Permanent Deformation**, AASHTO TP 79

**Flexural Fatigue**, AASHTO T321

**Low Temperature Creep and Strength**, AASHTO T322

**MAIN FEATURES**

- Extremely sturdy fabricated frame combined with precision machined components.
- Servo hydraulic vertical ram with integral hydraulic power supply.
- Precision electro-mechanical shearing motion (user programmable).
- Integral specimen extruder.
- Electronic control unit with touch screen color display (no need for PC).
- Unlimited memory storage with: 2 USB ports, 1 SD card slot, RS232/485 serial port.
- The compaction cycle can be programmed by specifying vertical stress/load and test termination conditions; Number of cycles, Specimen height and/or density.
- Precision load cell(s) for vertical and shear stress measurement.
- Optional built-in mould heater.

**THE MOST UNIFORM DENSITY OF ANY MACHINE**

Specimen is extruded after the machine has completed the specified number of cycles, or when the required specimen height has been reached.

An automatic extruder allows an easy extraction of the compacted specimen.

**B039A**

## TECHNICAL SPECIFICATION

<b>Vertical force</b>	Up to 100kN
<b>Shearing force</b>	Up to 50kN
<b>Shear angle</b>	$4^{\circ} \pm 0.1^{\circ}$
<b>Shearing cycle rate</b>	$3 \pm 0.1$ cycles per minute
<b>Mould width</b>	$150\text{mm} \pm 0.1 \text{ mm}$
<b>Mould length</b>	$450\text{mm} \pm 0.1 \text{ mm}$
<b>Mould surface finish (inside)</b>	Smoother than $0.4\mu\text{m rms}$
<b>Mould surface hardness</b>	More than 48 Rockwell C
<b>Mould capacity</b>	Approx. 20 litres
<b>Loading platen width</b>	$149 \text{ mm} \pm 0.2 \text{ mm}$
<b>Loading platen length</b>	$449 \text{ mm} \pm 0.2 \text{ mm}$
<b>Loading platen smoothness</b>	Smoother than $0.4\mu\text{m rms}$
<b>Loading platen surface hardness</b>	More than 48 Rockwell C
<b>Number of cycles</b>	Up to 100
<b>Vertical stress</b>	$0.1 \text{ to } 1.5\text{MPa} \pm 0.01\text{MPa}$
<b>Compaction height</b>	$0 \text{ mm to } 200 \text{ mm} \pm 0.1\text{mm}$

**Power supply:** 230V 1ph 50-60Hz  
**Dimensions:** 788x1360x1314 mm  
**Weight:** 1200 kg approx.

## A RUGGED DESIGN FOR THE BEST SPECIMEN PREPARATION

Asphalt technologists are acutely aware of the importance of a representative specimen during any laboratory performance testing. The precise shearing motion of the ASC replicates the conditions of field compaction in order to reproduce the field properties of asphalt, quickly and easily under the controlled conditions of a laboratory. The ASC compacts large asphalt prisms that can be sawn to produce four to six beams or slabs for laboratory wheel tracking; or the prism can be cored to produce three to four 100 mm diameter cylinders, all having essentially identical properties. The electronic control unit, with touch screen color display, makes a PC an option, not a necessity. The user friendly touch-screen icon interface allows for easy set up parameter entry, enables immediate (fully automatic test execution) data acquisition/processing, test report, and data file generation. A LAN connection to Intranet/Internet enables remote communication to receive immediate diagnostic analysis and technical support from Matest technicians, and/or software updates

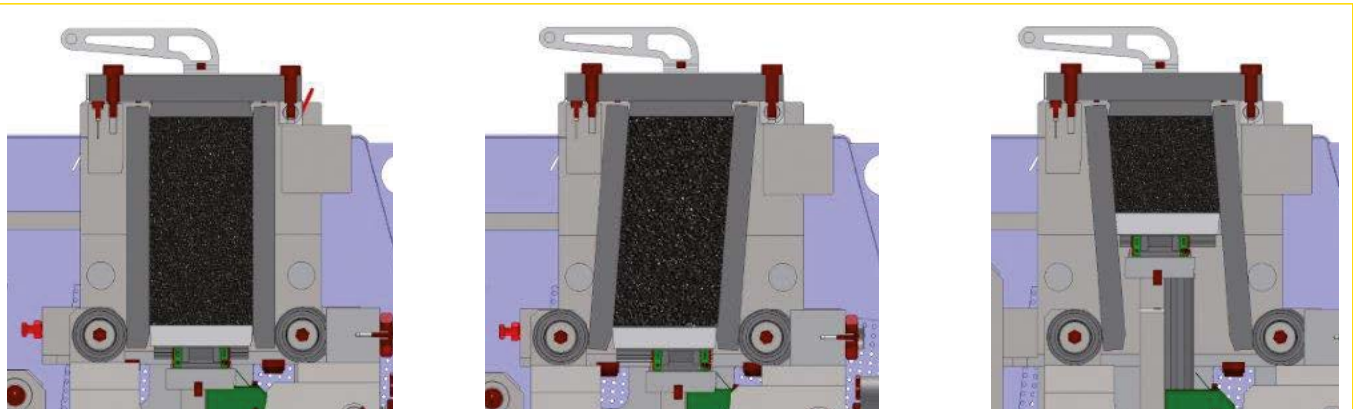

During the compaction process a lateral displacement is applied to the specimen along with a vertical load, which results in a shearing action that makes the compaction similar to the the field.

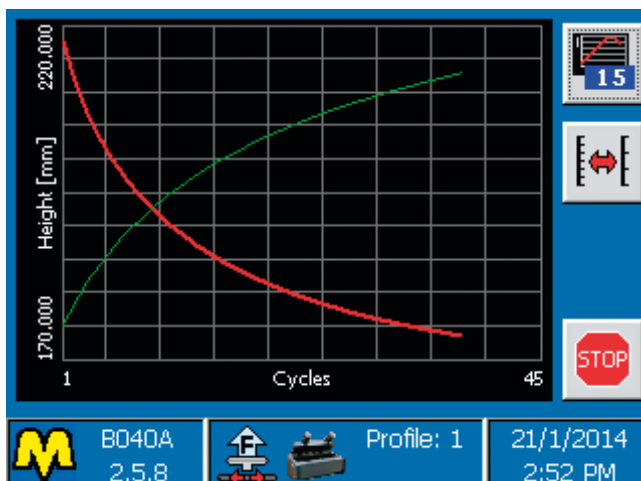

Height-Cycles and Density-Cycles curves during compaction

## ACCESSORIES

- B039A-01** LOADING CHUTE
- B039A-02** TRAY (2 off)
- B039A-03** SPREADING COMB
- B039A-04** LEVELING BLADE
- B039A-05** BUILT-IN MOULD HEATER (optional)

**B040M**
**APS**
**AUTOMATIC PAVE SAW**

## DUAL BLADE CONCEPT FOR PERFECT PARALLEL CUTTING

Matest has developed a dual bladed automated sawing system for fast, accurate cutting of rectangular beams, trapezoidal prisms, overlay test, semi-circular and trimming of cylindrical specimens. **APS** utilizes the **Cyber-Plus Progress control unit** for precise specimen cutting in compliance with **AASHTO, ASTM, and EN standards**. This advanced asphalt-cutting saw boasts safety and efficiency, eliminating the need for manual measurements. The machine cuts not only asphalt but also other materials. Capable of cutting prismatic specimens up to **240 mm high** and cylindrical specimens up to **200 mm in diameter**, the APS offers flexibility with one or two stainless steel blades and various fixtures for different specimen shapes. The controller enables easy speed and sequence control, while safety features, such as interlocks and a **protective enclosure**, ensure user safety during operation. APS includes: cooling water recirculation pump, tank and protection cabinet with interlocks to ensure operator safety.

**MAIN FEATURES**

- Adjustable cutting speed
- Jigs also available for trimming 100 and/or 150 mm diameter cylinders/cores
- Dynamic breaking system stops saw blade rotation when power is switched off
- Adjustable limit switches facilitates repetitive cutting with minimal saw carriage travel.
- Simple spacer system allows precise preparation of beams and cylinders from 38 mm to 160 mm long, without the need for measurement.

**B040M**
**TECHNICAL SPECIFICATIONS**

- Blade diameter(s): 650 mm or 700 mm
- Blade speed: 1400 rpm (50Hz) or 1680 rpm (60Hz)
- Adjustable cutting speed: min 40 mm/min, max 200 mm/min
- Max. cutting depth: 200 mm (with Ø 650 mm blade) or 240 mm (with Ø 700 mm blade)
- Dimensions 2370x1340x160 mm
- Weight: 500 kg approx.
- Power Supply:
  - 400V 50Hz 3ph, 230V/220V 50Hz 3ph (B040M)
  - 400V 60Hz 3ph, 230V/220V 60Hz 1ph (B040X)
  - 208V 60Hz 3ph (B040Z)

**ACCESSORIES**

- B040-01** APS DIAMOND BLADE, 650 mm diameter (q.ty 1 or 2) or
- B040-02** APS DIAMOND BLADE, 700 mm diameter (q.ty 1 or 2)
- B040-03** SET OF SPACERS for mounting the APS Diamond blade, 650 mm diameter (needed for B040-01)
- B040-04** SET OF SPACERS for two blades configuration (needed for two blades configuration)
- B040-05** SPACER for one blade configuration (needed for one blade configuration)
- B040-06** DISPLACEMENT TRANSDUCER for the control of the blade position
- B040-07** PNEUMATIC CIRCUIT (needed with Pneumatic cutting jigs)

If equipped with pneumatic cutting jigs, the unit requires compressed air, minimum 8 bar

**CUTTING JIGS**

- B040-10M** APS manual Multi-Slab/Prism jig suitable for slabs and prisms with the following dimensions: 40 - 240 mm depth x 700 mm length.
- B040-10P KIT** APS automatic Multi-Slab/Prism jig suitable for slabs and prisms with the following dimensions: 40 - 240 mm depth x 700 mm length.
- B040-12M** APS manual trapezoidal specimen jig for two point bend (it requires B040-10M or B040-10P-KIT).
- B040-13M** APS manual core docking jig for Ø 150-100-60-50-40-38 mm cores.
- B040-13P** APS automatic core docking jig for Ø 150-100-60-50-40-38 mm cores.
- B040-14** Instrumentation for Overlay test, wheel tracking core, semi-circular and disk shaped compact tension specimens (it requires B040-13M or B040-13P).

**B040-20****ACD****AUTOMATED CORE DRILL**

Matest has developed an Automated Core Drill (ACD) for fast, accurate cutting of cores from cylinders, prisms and slabs prepared using Matest's range of asphalt compaction machines; GYROTRONIC-Gyratory Compactor, ASC-Asphalt Shear-box Compactor and field specimens for subsequent testing using Matest/Pavetest's range of leading edge testing systems.

**MAIN FEATURES**

- Three selectable drill speeds.
- Clear protective/splash screen conforming to CE standards.
- Ideal for coring prismatic specimens compacted in Asphalt Shear-box Compactor (ASC).
- Suitable to core cylindrical specimens compacted in Gyratory compactor(s).
- Includes water container/tray.
- Adjustable specimen clamp eliminates specimen movement during coring.
- Three position fixture provides easy and accurate specimen positioning.
- Three core supports at fixed spacing yields two or three cores from one prism.
- Optional cylindrical specimen jig.

**B040-20****SPECIFICATIONS**

Drill Bit Diamond/tungsten alloy, laser welded.

Core diameter 100 mm or 150 mm.

For other core diameters, see the accessories.

Core height up to 40 cm.

Specimen sizes:

- Cylindrical Sample: 160 mm x 70 mm - 400 mm ( $\varnothing$ xH)
- Prismatic Sample:  
200-450 mm x 150-185 mm x 120-420 mm (LxDxH)  
315-340 mm x 220-260 mm x 120-420 mm (LxDxH)

**Dimensions:** 60 cm (L) x 80 cm (D) x 140 cm (H)

**Net weight:** 85 kg

**Power supply:** 230V 10A 50Hz 1ph (540/1, 300/1, 800 rpm)  
230V 10A 60Hz 1ph (560/1, 330/1, 850 rpm)  
115V 20A 60Hz 1ph (560/1, 330/1, 850 rpm)

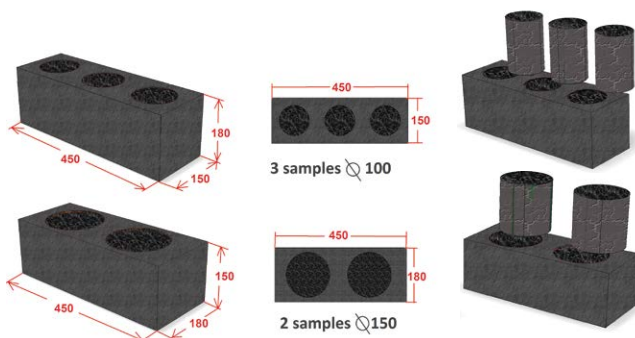
**MODELS**

**B040-20** Asphalt Core Drill (230V/50-60Hz) for prisms

**B040-20Y** Asphalt Core Drill (110V/60Hz) for prisms

**ACCESSORIES**

**C339-03B**  $\varnothing$  101.5  $\pm$  1 mm x 420 mm long (needed)

**C339-04**  $\varnothing$  150 x 420 mm long drill bit (needed)

**B040-21** Clamping cylindrical specimen jig to suit from 50 to 150 mm diameter specimens (needed)

**B040-22 KIT** DCT specimen. It includes:

■ **B040-22** DCT specimens drilling jig

■ **B040-33**  $\varnothing$  25 x 420 mm long drill bit

**B040-21**

**B040-23 KIT** Transversal coring. It includes:

■ **B040-23** Transversal coring jig

■ **C339-02**  $\varnothing$  75 x 420 mm long drill bit

■ **B040-30**  $\varnothing$  38 x 420 mm long drill bit

■ **C339-01**  $\varnothing$  50 x 420 mm long drill bit

**B040-31**  $\varnothing$  42 x 420 mm long drill bit

**B040-32**  $\varnothing$  55 x 420 mm long drill bit

**C346** Core Extractor  $\varnothing$  50 mm

**C346-01** Core Extractor  $\varnothing$  75 mm

**C346-02** Core Extractor  $\varnothing$  100 mm

**C346-03** Core Extractor  $\varnothing$  150 mm

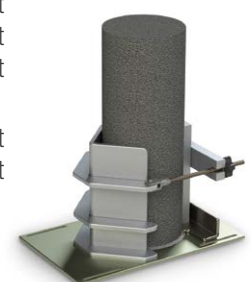
**B040-21**

**B038AM**

**SMARTRACKER™**

**MULTI WHEELS HAMBURG WHEEL TRACKER;** TEST ENVIRONMENT: DRY AND WET

STANDARDS: EN 12697-22 | AASHTO T-324

PATENT No: US 9, 964, 471

itTECH

**CYBER  
PLUS**  
PROGRESS

**PATENTED**



**B038AM**

**THE N° 1 UNIT IN U.S. MARKET**

#### MAIN FEATURES

- Meets and exceeds AASHTO and EN Standards.
- Simultaneous testing of wet and dry samples.
- Independent motors for each wheel assure separate rutting analysis of each specimen.
- Wheels retract automatically.
- Sturdy machine, designed for the rugged construction laboratory environment.
- Sliding sample positioning mechanism for easy mould handling and placement in the machine.
- Cyber Plus Progress technology allow to apply a load with a perfect sinusoidal wave in accordance with AASHTO T-324:19.
- Fully Automatic machine. Detects and stops the test when the target rut depth is reached.
- Touch-screen control unit and new icons for a modern and user friendly approach.
- Each of the two wheel assemblies is equipped with displacement transducers for rut measurement.
- Mechanical recirculating water bath for temperature control within  $\pm 1$  °C.
- Easy to load, unload, drain water and clean the unit after each test.
- Compact design to accommodate small construction labs and make maintenance easier.
- Covered by US Patent.

**B038AM**  
**SMARTRACKER™**  
 MULTI WHEELS HAMBURG WHEEL TRACKER - **PATENTED**

STANDARDS: EN 12697-22 | AASHTO T-324

The Hamburg wheel tracking device can be used to determine the resistance of Hot Mix Asphalt (HMA) to rutting, stripping and moisture sensitivity. Matest model "SmarTracker™" meets and exceeds EN and AASHTO.

It is intelligently designed with innovative features and the needs of the end users in mind.

The most versatile wheel tracker on the market has independent motors for each wheel which assure separate rutting analysis of each specimen.

**Now you can perform wet or dry test with both wheels or run one wheel under dry and one wheel under wet condition simultaneously during a single test.**

Determine the creep slope, stripping inflection point and mean wheel-tracking slope with this state of the art and user friendly machine.

Equipped with the latest Cyber Plus Progress, Matest Smartracker controls the movement of the wheels in order to obtain a perfect sinusoidal wave. The measurement points for defining the rut depth are completely customizable according to EN or AASHTO Standard and for research purposes. MATEST SmarTracker™ has been developed by our R&D engineers and scientific in association with some of the most experienced and reputable industry experts in the USA and the world.



Unique system to Load-unload the mould



Innovative wheels roll off Mechanism (patented)

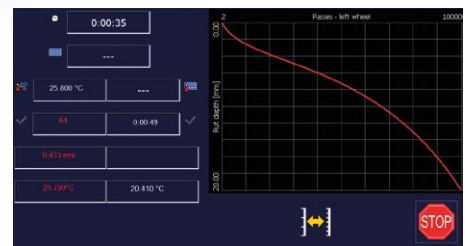

Real time results plot of the rut depth along with the no. of passes.

TABLE OF ACCESSORIES TO PERFORM DRY (AIR) AND WET (WATER) TEST FOLLOWING - EN 12697-22 AND AASHTO T324 SPECIFICATIONS

Standards	EN 12697-22		AASHTO T324	
Testing mode	Dry (air)	Wet (water)	Wet (water)	* Dry (air)
	2x <b>B038A-01</b> Rubber wheel	2x <b>B038A-01</b> Rubber wheel	2x <b>B038A-02</b> Steel wheel	2x <b>B038A-02</b> Steel wheel
	2x <b>B038A-11</b> EN Mould	2x <b>B038A-11</b> EN Mould	2x <b>B038AM-06</b> Probe (optional)	2x <b>B038A-10</b> or 2x <b>B038A-11</b> Mould
	2x <b>B038A-12</b> 2x <b>B038A-13</b> Adaptors	2x <b>B038A-12</b> 2x <b>B038A-13</b> Adaptors	FOR CYLINDRICAL SPECIMENS: 2x <b>B038A-10</b> AASHTO Mould	2x <b>B038A-03</b> Support for AASHTO Mould
	<b>B038A-05</b> Air heating	<b>B038AM-06</b> Probe (optional)	2x <b>B038A-03</b> Support for AASHTO Mould	2x <b>B038A-12</b> + 2x <b>B038A-13</b> Adaptors
	2x <b>B038A-06</b> Probe (optional)		<b>B038A-10D</b> Adaptors	<b>B038A-05</b> Air heating
	<b>B038AM-06</b> Probe (optional)		FOR SLAB SPECIMENS: 2x <b>B038A-11</b> Mould	2x <b>B038A-06</b> Probe (optional)
			<b>B038A-12+B038A-13</b> Adaptors	<b>B038AM-06</b> Probe (optional)

**B038A-01**

Rubber wheel for EN 12697-22

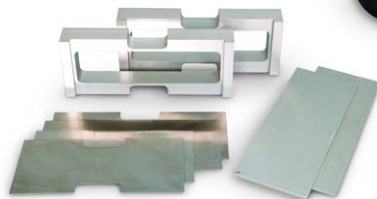

**B038A-13** Horizontal adaptors for EN moulds

**Note:** \*AASHTO T324 does not require air test.



**B038A-11** EN mould



**B038A-02**  
Steel wheel for AASHTO T324

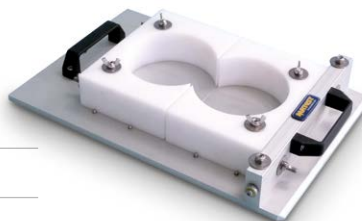

**B038A-10**  
AASHTO mould



**B038A-14**

**NEEDED ACCESSORIES**

**EN 12697-22**

- B038A-01** RUBBER WHEEL 203x50 mm
- B038A-11** EN MOULD 400x305x120 mm
- B038A-12** SET OF VERTICAL ADAPTORS for EN mould to allow the positioning of specimens lower than 120 mm (up to a minimum specimen thickness of 20 mm)
- B038A-13** SET OF HORIZONTAL ADAPTORS for EN mould to allow the positioning of specimens 260x320 mm and 305x305 mm

**AASHTO T324**

- B038A-02** STEEL WHEEL 203x47 mm
- B038A-10** AASHTO MOULD (2 cylinders Ø 150x60 mm)
- B038A-03** TOOL for AASHTO positioning
- or
- B038A-07** STAINLESS STEEL SUPPORT for AASHTO positioning
- B038A-10D** VERTICAL ADAPTORS for AASHTO mould to allow the positioning of specimens with a thickness of 40 mm
- B038A-08** Rubber wheel Ø 203x50 mm
- B038A-10SP** BS mould (one cylinder Ø 200x60 mm)
- B038A-03** or **B038A-07** for positioning.

**OPTIONAL ACCESSORIES**

- B038A-04** ELECTROVALVE group for hot water
- B038A-05** AIR HEATING SYSTEM for air conditioning test EN 12697 -22
- B038A-06** PROBE for specimen's temperature determination
- B038A-09** HPDE mould specimen holder.
- B038A-14** VERIFICATION KIT for the calibration of the wheel load. The device is composed of a support block with a calibrated load cell and complete with a digital readout. Max. load 1000 N, accuracy 0.05%.
- B038A-08** RUBBER - tyre wheel 203x50 mm to australian AG:PT/T231 Spec.
- B038A-16** SOFTWARE HWT-Report to AASHTO T324

**TECHNICAL SPECIFICATIONS**

- Wheel load: 705 N
- Wheel speed: from 20 to 30 cycles/minute.
- Number of cycles: up to 30000 cycles.
- Temperature control:  
EN 12697-22: 2500W heaters for air temperature control, ventilation for temperature uniformity, probe for air temperature, all controlled by the electronic system.  
AASHTO T324: 4000W heaters, recirculating pump, automatic feed and controls level.
- Temperature control range: from ambient up to 75° ± 1 °C
- Table travel: 230, 260, 280 mm
- Rut depth transducers range: 25 mm ± 0.1 mm accuracy.
- Slab thickness: adjustable from 38 to 120 mm

**Power supply:** 220V 50-60Hz  
**Dimensions:** 1400x1300x1300 mm  
**Weight:** 450 kg approx.

**MAIN FEATURES**

- No added stress to operators back from lifting heavy wheel assemblies.
- Sample holders slide into position and eliminate demanding lifting and placement of samples into the unit.
- Hood keeps technicians away from moving parts and provides better temperature control while the test is being conducted.

**B038AM-15  
 SMARTRACKER HAMBURG VERSION AASHTO T324  
 (WATER TEST ONLY)**

STANDARDS: AASHTO T324, AMAAC Mex Protocol  
 Same as model B038A but without cover, it allows water test only.



**B038AM-15**

**TESTING SOFTWARE**

The user-friendly software is integrated into the on-board digital control unit based on Windows operating system. The software is fully customizable by the operator according to EN and AASHTO Standards, and the personal needs. Automatic calculation of stripping inflection point (AASHTO). Test execution and all parameters, such as water/air temperature, specimen temperature, rut depth can be monitored in real time. The software also allows exporting test data to an Excel compatible format.

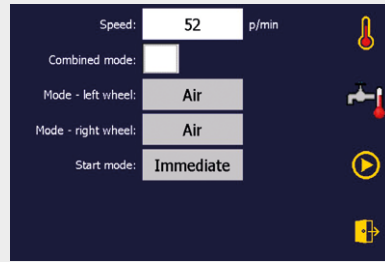

**B038A-16 SOFTWARE HWT-REPORT TO AASHTO T324**

The Unique HWT-Report software allows the user to analyze the results from the SmarTracker to generate a report and a graph strictly conforming to AASHTO T324. The features of the software include the ability to analyze different locations along the wheel pass, graph maximum and average rut depths, stripping inflection point and detailed reports (selecting all the wheel passes or different sampling rates) that can be presented, printed or emailed.

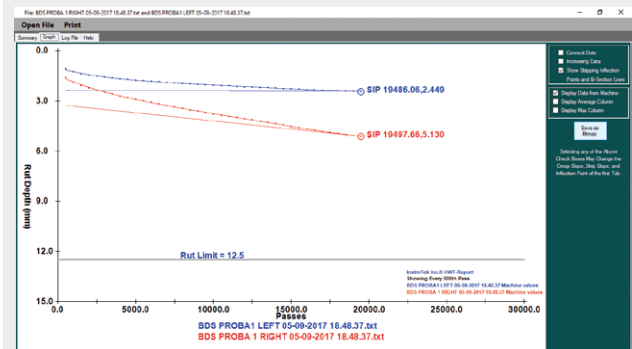

Left Pass	Left Rut Depth	Left Temp °C	Right Pass	Right Rut Depth	Right Temp °C	Difference
4000	1.24	59.9	4000	1.14	58.2	0.10
8000	1.39	60.2	8000	1.09	58.9	0.30
12000	1.47	60.2	12000	1.20	60.2	0.27
16000	1.53	60	16000	1.09	60	0.44
20000	1.68	60.2	20000	1.47	60.2	0.21
24000	1.44	59.9	24000	1.19	59.9	0.25
28000	1.89	60.1	28000	1.79	60.1	0.10
32000	1.70	60.2	32000	1.47	60.2	0.23
36000	1.78	60	36000	1.21	60	0.57
40000	1.79	60.1	40000	1.09	60.1	0.70
44000	1.83	60	44000	1.07	60	0.76
48000	1.85	60.1	48000	1.17	60.1	0.68
52000	1.89	60.1	52000	1.27	60.1	0.62
56000	1.93	60	56000	1.39	60	0.54
60000	1.97	60	60000	1.44	60	0.53
64000	1.97	60	64000	1.44	60	0.53
68000	1.97	60	68000	1.44	60	0.53
72000	1.97	60	72000	1.44	60	0.53
76000	1.97	60	76000	1.44	60	0.53
80000	1.97	60	80000	1.44	60	0.53
84000	1.97	60	84000	1.44	60	0.53
88000	1.97	60	88000	1.44	60	0.53
92000	1.97	60	92000	1.44	60	0.53
96000	1.97	60	96000	1.44	60	0.53
100000	1.97	60	100000	1.44	60	0.53
104000	1.97	60	104000	1.44	60	0.53
108000	1.97	60	108000	1.44	60	0.53
112000	1.97	60	112000	1.44	60	0.53
116000	1.97	60	116000	1.44	60	0.53
120000	1.97	60	120000	1.44	60	0.53
124000	1.97	60	124000	1.44	60	0.53
128000	1.97	60	128000	1.44	60	0.53



## CDAS2

### CONTROL AND DATA ACQUISITION SYSTEM

Pavetest's compact Control and Data Acquisition System (CDAS2) delivers unparalleled performance, real time control and ultimate versatility in acquisition and provide a flexible and user friendly testing solution.

**It provides excellent waveform fidelity from integrated acquisition and control functions, with low level sampling at speeds of up to 200,000 samples per second simultaneously on all channels and 24 bit resolution over the full dynamic input signal range.**

#### MAIN FEATURES

- Directly communicates with the TestLab software, providing automatic test execution and data processing.
- Compact high reliability data acquisition and control.
- Up to 5 kHz data acquisition and feedback control provides excellent waveform fidelity.
- Up to 64 times oversampling gives superior low noise performance.
- Normalized ( $\pm 10$  V) analog data acquisition inputs provide flexibility to use any transducer in any channel.
- Automatic recognition of transducers and upload of calibration files.



**B209-16** CDAS2 16 channels

#### EASY DATA PROCESSING WITH THE INCLUDED SOFTWARE

The CDAS2 includes the TestLab software - supplied on USB flash drive - complete with relevant Method files (based on the test configurations supplied) and calibration files for all the transducers supplied. Software and test methods are expandable for future requirements.

#### AVAILABLE MODELS

##### B209-08

**8 Channel CDAS2** - Acquisition 8 CH, 24 bit resolution

- Sampling rate up to 200 kHz (all channels)
- Smoothing up to 64 times over-sampling
- Calibration Automatically on power up
- Control Axis 2
- Communication USB or Ethernet

##### B209-16

**16 Channel CDAS2** - Acquisition 16 CH, 24 bit resolution

- Sampling rate up to 200 kHz (all channels)
- Smoothing up to 64 times over-sampling
- Calibration Automatically on power up
- Control Axis 4
- Communication USB or Ethernet

- Up to 24 CH, 6 Axis CDAS2 also available on request

**Dimensions:** 110(h) x 325(d) x 265(w) mm

**Power Supply:** 90-264V 50-60Hz 1ph 240W

**Weight:** 5 kg approx.

#### TECHNICAL FEATURES

##### CONTROL:

- Up to 6 high speed, (18 bit) digital servo-control, axis.
- Digital closed loop update sampling rate of 5 kHz per axis.
- Computer programmable, Proportional, Integral and Derivative (PID) control algorithm.
- Adaptive Level Control (ALC) algorithm for best dynamic peak accuracy.
- 3 feedback control modes. E.g. force, position and on-specimen strain.
- "Bumpless transfer" between control modes.

##### ACQUISITION:

- Analog inputs are automatically calibrated on power up.
- Simultaneous sampling of all channels.
- Up to 24 analog ( $\pm 10$  Volt) input channels.
- Up to 64 times over sampling (set to 8 by default).
- 24 bit digital resolution (**approx. 1/16,777,216**), no auto ranging required.
- Sampling rate up to 200.000 samples/see.

## TESTLAB SOFTWARE

Developed with ultimate flexibility in mind, TestLab test and control software caters to all levels of operator experience. By using pre-programmed **Method files**, an inexperienced operator can run a range of international test methods without the need for any programming. Moreover, a test **Wizard**, available with popular tests, can guide the operator step by step based on a recipe book approach. Most importantly, the experienced engineer and/or researcher need not be constrained by the functions and analysis in the method files provided. The operator may clone, modify and/or generate his/her own method file to suit their specific requirements. The Excel based data analysis offers the operator the flexibility to implement alternative analysis and customize reporting facilities. TestLab allows for real time graphing of results and configurable real time transducer levels display with unprecedented clarity of results and analytical power.

### MAIN FEATURES

- Open architecture software allows user to inspect calculations and results.
- Integrated data result post processing feature with MS Excel.
- Standard and user customizable test reporting.
- Real time graphing of results and configurable real time transducer.
- Flexible and user-friendly with unprecedented clarity of results and analytical power.
- Full access for advanced user to specify their own calculations, test results and charting.



## TESTLAB, A NEW APPROACH

TestLab is an open architecture user programmable software application. Our engineers have taken the time to review all the relevant international test standards and used TestLab **Test Designer** to program method files according to these standards. Basically, any of these tests can be designed, cloned and/or modified by the user within TestLab. The user is no longer restricted to the test applications provided at time of purchase the possibilities are only limited by the skill and imagination of the user.

### TESTLAB MANAGER

The Testlab materials testing software is a universal approach to materials testing and is designed to interface the CDAS2 – Control and Data Acquisition Systems - and the wide range of Pavetest machines. A Testlab Manager interface allows users to easily and efficiently locate the necessary method files to load and execute.

### TEST METHOD SELECTION

The operator can run pre-programmed Method files, in accordance to the requested Standards, or configure an application test and then save that configuration to a customised Method file. This includes the transducer and calibration allocations, control parameters, termination conditions and any other items, which allow users to enter data. Method files may easily be “cloned”, adapted and saved to be used at a later stage with pre-set preferences.

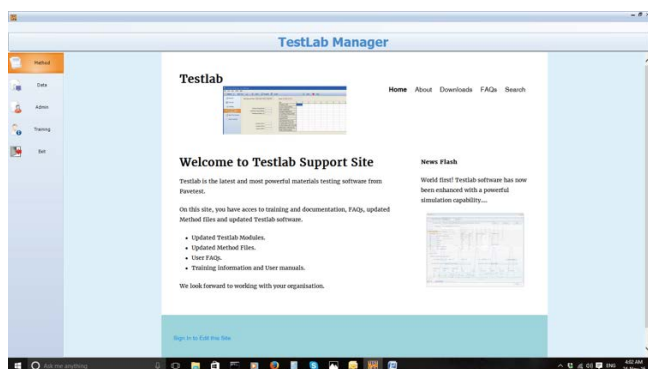

Testlab Manager

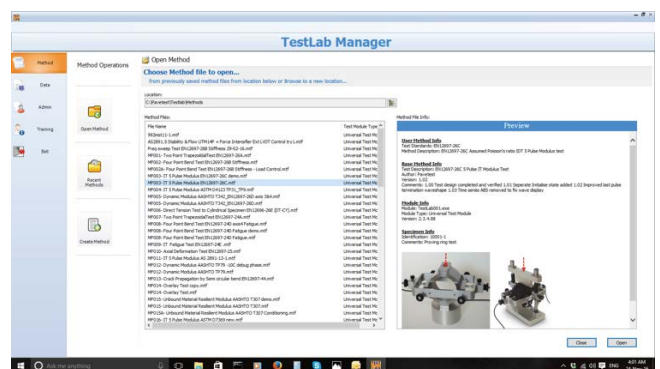

Selection of Method Files

## TESTLAB, USER FRIENDLY INTERFACE

### TEST WIZARD

The wizard section provides a prompted menu approach to running a test. The user is driven to enter information throughout a series of easy steps.

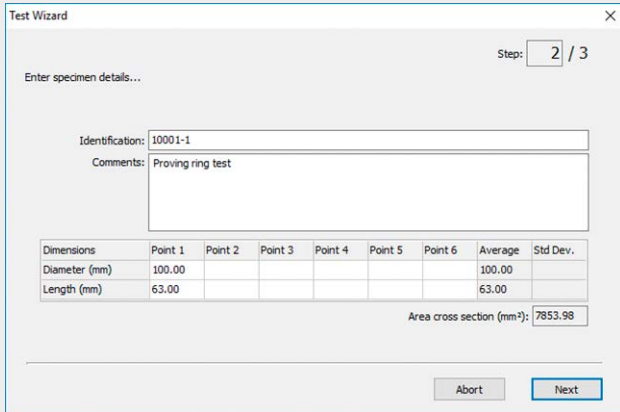

User guided Test wizard

### TESTLAB UNIVERSAL TEST

The Test Data section displays run-time information, such as the loading time, cycle count, transducer readings (force, displacement, pressure, temperature), stress calculations, strain calculations and other test specific properties.

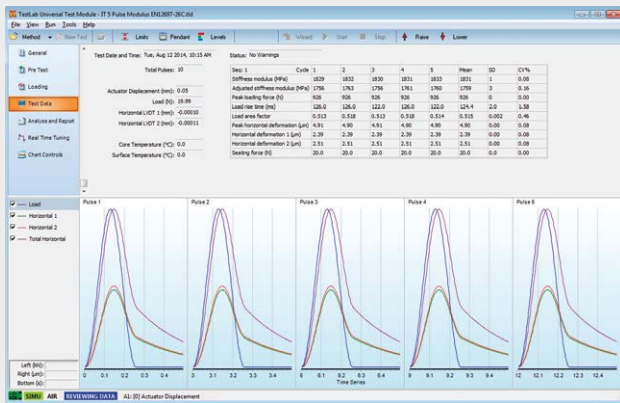

Test Data - EN12697-26C Indirect tension to cylindrical specimens

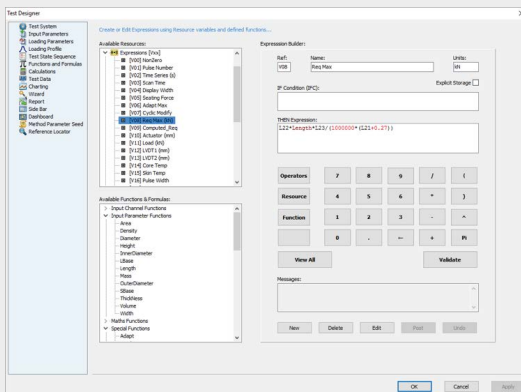

Test designer – Expressions and calculations editor

### REAL TIME DASHBOARD DISPLAY

For the more sophisticated tests, Pavetest provides the user with an alternative, simpler and more intuitive representation of the current status of both machine and test method. This dashboard display feature of TestLab shows real time transducer levels, computed data and charted data before, during and after the test has completed.

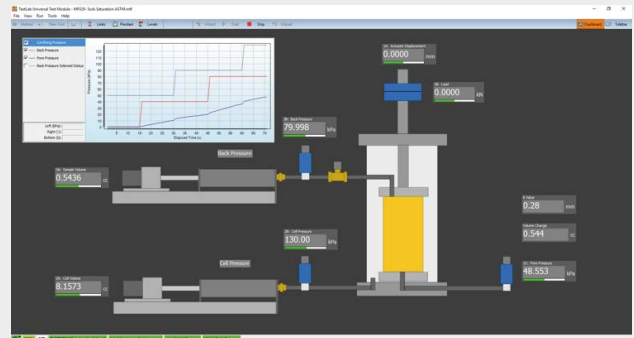

Typical dashboard screen

### POST PROCESSING

All Testlab Method file tests provide the facility to send the data directly to an Excel workbook including test input and results data. This facility provides a means of efficiently post processing raw data results and customizing reports from within Excel and optionally displaying summary result in TestLab.

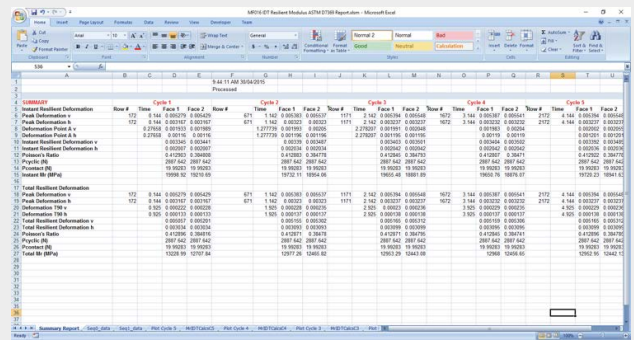

Post processing summary results

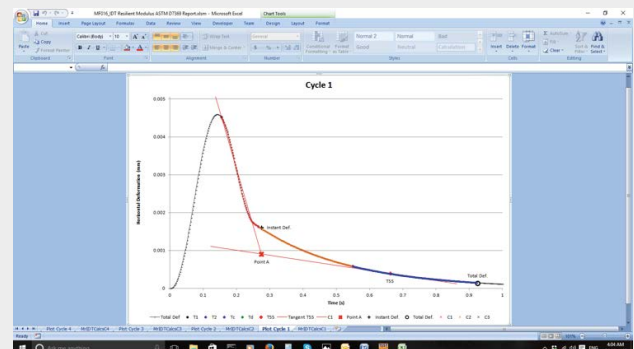

Excel post processing report

## UPGRADE YOUR UNIVERSAL TESTING MACHINE

It is a well-known fact that the controller and software is one of the most important aspect of any system and the main reason testing machines become outdated or obsolete.

**Pavetest has now made it easier than ever to upgrade third party servo-hydraulic/pneumatic dynamic testing machines,** to Pavetest's leading-edge Control and Data Acquisition System (CDAS2) and world acclaimed TestLab software.

### MAIN FEATURES

- TestLab Software provides powerful and flexible solution.
- Comprehensive suite of pre-programmed Method Files.
- Ability to create your own Method Files.
- Adaptable for existing transducers.
- In-line signal conditioners.
- Interfaces to most third party Hydraulic Power Supplies.

### TESTLAB PC SOFTWARE

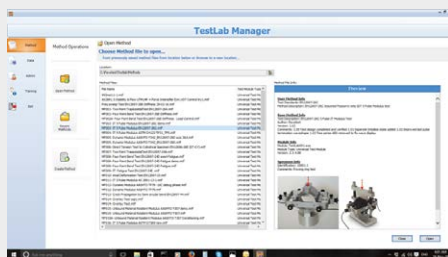

Selection of Method Files

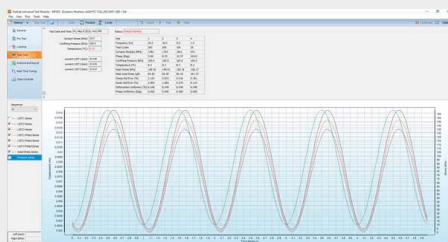

Test Methods



Typical dashboard screen



CDAS2 and HPS interface

### THIRD PARTY TESTING MACHINES

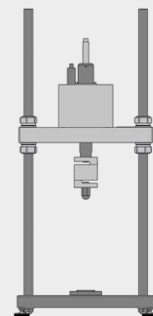

Servo Pneumatic test machine

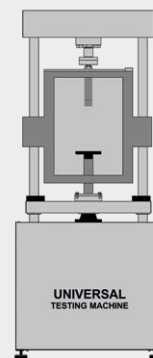

Servo Hydraulic test machine

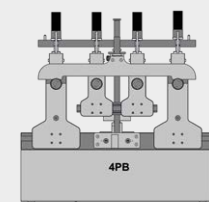

4 PT Beam test machine

**B265**
**SMARTPULSE ALL-IN-ONE**
**18 kN ELECTRO-MECHANICAL DYNAMIC TESTING SYSTEM**

SmartPulse is an **electro-mechanical servo-controlled dynamic testing** machine adopting a high-performance long-duration electro-mechanical actuator. It is engineered to deliver precise testing capabilities across tension, compression dynamic loading and is suited to testing a diverse range of materials such as asphalt and other construction materials. This versatile functionality reduces the need for multiple testing machines, optimizing resource utilization.

SmartPulse boasts **18 kN capacity in dynamic** load and **12 kN in static** load. The machine is provided with a gearmotor, so it doesn't require the need for an external compressor or pump. Unlike traditional hydraulic systems that consume large amounts of energy, SmartPulse's electro-mechanical technology minimizes resources consumption without compromising accuracy.

Key to its design is the integrated climatic chamber with low consumption thermoelectric conditioning ensuring uniform temperature distribution. The **small window** at the front is designed to allow access to the test space with **minimal impact on the chamber temperature**. Thanks to this feature, the machine keeps the temperature stable, reducing the energy consumption. Users can easily monitor and adjust temperature settings via PC or thermoregulator.

SmartPulse is complemented by Pavetest's **CDAS2** digital controller and **TestLab** software, offering comprehensive integration for seamless operation and precise data analysis.

**MAIN FEATURES**

- Compact, fully self-contained, precision engineered unit.
- Precision electro-mechanical actuator (silent operation).
- Integrated climatic chamber.
- Fully configurable to suit a large range of testing applications.
- A gull-wing door offering a wide test area with three accessible sides.

**B265**

## TECHNICAL SPECIFICATIONS

### Load frame

- Between Columns 380 mm
- Vertical Space 778 mm

### Servo actuator

- Actuator Stroke 50 mm
- Frequency up to 100 Hz
- 12 kN Static load
- 18 kN Dynamic load

**Temperature range:** 2 to 60 °C (thermoelectric unit)  
-10 to 60 °C (refrigeration unit, model B265-01)

**Power supply:** 230V, 50Hz, 1ph, 10A  
110V, 60Hz, 1ph, 19A

**Dimensions:** 1900(h) x 1000(d) x 850(w) mm

**Weight:** 380 kg approx.

## TECHNICAL FEATURES

- **Electro-mechanical unit.** The machine applies static or dynamic waveform loading either in load or displacement control to a specimen.
- **The system comprises** a load frame, a load cell, Control Data Acquisition System (CDAS) and an insulated chamber.
- **Portable refrigeration unit.** We offer several models of refrigeration unit, with different temperature ranges, to cover a number of international testing standards.



A small window offering access to the test space with minimal disruption to the chamber temperature.



Thermoregulation display to monitor the temperature in real time.



**B265-01** 18 kN ELECTRO-MECHANICAL DYNAMIC TESTING SYSTEM similar to model B265 but with a refrigeration unit having an extended temperature range from -10 °C to +60 °C (with inbuilt water cooling system)

## RECOMMENDED ACCESSORIES

**B250-07 KIT** Temperature measuring kit comprising:

- **B292-01N** Temperature transducer (-80 °C to +80 °C) (2 pieces)
- **B250-10** Dummy asphalt specimen
- **B250-11** 100 mm "O" ring (3 pieces)
- **B250-12** Thermal conducting grease (about 56 g)

**H009-01EN** PC complete with LCD monitor 22", keyboard, mouse, cables and installation of Testlab software

For test configurations and related jigs, please consult p. 36-47



Recirculation fans ensuring uniform temperature in the chamber.

## 16 kN SERVO-PNEUMATIC DYNAMIC TESTING SYSTEM

TWO MODELS AVAILABLE:

### B220-01 KIT DTS-16 WITH MANUAL CROSSHEAD

### B220-02 KIT DTS-16 WITH MOTORIZED CROSSHEAD

The DTS-16 Dynamic Testing System is a servo-pneumatically controlled testing machine utilizing digital control of a pneumatic servo valve to provide accurate loading wave shapes up to 70 Hz. The DTS-16 can be operated in tension, compression dynamic loading and is suited to testing a diverse range of materials such as asphalt, soil, unbound granular materials, fibres and plastics.

The DTS-16 is underpinned by Pavetest's leading edge CDAS2 digital controller, TestLab software and a full complement of accessories, hardware and software in perfect unison.

#### MAIN FEATURES

- Compact, robust 2-Column load frame.
- Precision engineered.
- Optional Motorized crosshead positioning.
- Fully configurable to suit a large range of testing applications.
- Digital Servo-Pneumatic control.
- 4 axis control and 16 Channel Control and Data Acquisition System.

The machines includes:

**B220-11** 20 kN Load frame with manual crosshead,  
16 kN Servo-pneumatic actuator with its  
LVDT (30 mm stroke),  $\pm 20$  kN load cell

or

**B220-12** 20 kN Load frame with motorized crosshead,  
16 kN Servo-pneumatic actuator with its  
LVDT (30 mm stroke),  $\pm 20$  kN load cell  
+

**B209-16** 16 Channel Control and Data Acquisition System  
(CDAS2) & TestLab software

**B270-12** Air reservoir assembly with membrane dryer

It requires pressurized air, minimum 7 bar (not included).



#### B220-02 KIT

16 kN Servo-Pneumatic dynamic testing system (motorized crosshead) with **B221** Temperature controlled cabinet

Model	B220-01 KIT	B220-02 KIT
B220-11	▼	
B220-12		▼
B209-16	▼	▼
B270-12	▼	▼

## TECHNICAL SPECIFICATIONS

### Load frame

- Between Columns 345 mm
- Vertical Space 650 mm

### Servo actuator

- Capacity  $\pm$  16 kN
- Frequency up to 70 Hz
- Stroke 30 mm
- Air supply clean dry air
- Pressure 800-900 kPa
- Minimum rate up to 5 litres/sec

**Power Supply:** 90-264V 50-60Hz 1ph 240W (B220-11)  
230V 50Hz 1ph 100W (B220-12)  
230V 50Hz 1ph 1450W (B221)

**Dimensions:** 1262(h) x 400(d) x 470(w) mm B220-11 load frame  
1262(h) x 400(d) x 510(w) mm B220-12 load frame  
2170(h) x 840(d) x 760(w) mm load frame with  
temperature controlled cabinet

**Weight:** 80 kg load frame B220-11 load frame  
125 kg load frame B220-12 load frame  
160 kg temperature controlled cabinet



**B220-02 KIT**  
DTS-16 detail

**B220-12**  
20 kN Load frame with motorized  
crosshead

## TECHNICAL FEATURES

### ■ Optional motorized crosshead.

A motorized crosshead allows an easier test set-up in terms of accessories positioning without using any extension rods.

### ■ Latest technology.

The DTS-16 advantage revolves around the Control Data Acquisition System (CDAS2) and TestLab Software.

### ■ Durable powder coated aluminium base plate with stainless steel work platen.

### ■ Air reservoir assembly with membrane dryer.

It provides protection to the servo-valve from moisture in the compressed air supply.

## RECOMMENDED ACCESSORIES

- B221** Temperature controlled cabinet: -30 °C to +70 °C  
to suit DTS-16 or 4PBA
- B250-07 KIT** Temperature measuring kit comprising:
- **B292-01N** Temperature transducer (-80 °C to +80 °C)  
(2 pieces)
  - **B250-10** Dummy asphalt specimen
  - **B250-11** 100 mm "O" ring (3 pieces)
  - **B250-12** Thermal conducting grease (about 56 g)
- H009-01EN** PC complete with LCD monitor 22", keyboard,  
mouse, cables and installation of Testlab software

**B270-12**  
Air reservoir assembly  
with membrane dryer



**B250-07 KIT**  
Temperature measuring kit

For test configurations and related jigs, please consult p.36-47

## B230 30 kN SERVO-HYDRAULIC DYNAMIC TESTING SYSTEM (DTS-30)

The DTS-30 Dynamic Testing System is a servo-hydraulic testing machine utilizing digital control of a high performance servo valve to provide accurate loading wave shapes up to 100 Hz. The DTS-30 can be operated in tension, compression dynamic loading and is suited to testing a diverse range of materials such as asphalt, soil, unbound granular materials, fibres and plastics. The DTS-30 is underpinned by Pavetest's leading edge CDAS2 digital controller, TestLab software and a full complement of accessories, hardware and software in perfect unison.

**The DTS-30 Dynamic Testing System is compact, fully integrated, user and environmentally friendly.**

### MAIN FEATURES

- Compact, robust load frame.
- Small footprint; 90 cm x 135 cm, including hydraulic power supply and climatic chamber.
- Reaction frame embedded in the test chamber.
- Portable temperature control unit.
- Fully configurable to suit a large range of testing applications.
- Digital Servo-Hydraulic control.
- Dynaflo™ HPS provides dynamic speed control of the pump motor ensuring quiet operation.
- 4 axis control and 16 channel data acquisition as standard.

The machine includes:

- Rigid two column load frame
- 30 kN Servo-hydraulic actuator (100 mm Stroke)
- 2.2 kW Hydraulic Power Supply
- 16 Channel Control and Data Acquisition System (CDAS2) & TestLab software
- Load cell ( $\pm 30$  kN)
- 100 mm actuator LVDT



**B230 30 KN**  
 Servo-Hydraulic  
 Dynamic Testing System with B232 temperature controlled cabinet

## TECHNICAL SPECIFICATIONS

### Load frame

- Between Columns 600 mm
- Vertical Space 800 mm

### Servo actuator

- Capacity  $\pm 30\text{kN}$  static,  $\pm 25\text{kN}$  dynamic
- Frequency up to 100Hz
- Stroke 100 mm

### Hydraulic Power Supply

- Pressure up to 160 bar, user defined
- Flow rate up to 7.5 litres/min
- Dimensions: 650(h) x 550(d) x 450(w) mm
- Power Supply: 230V 50-60Hz 1ph 2.5kW

### Power Supply:

- 230V 50-60Hz 1ph 2.5kW (B230)
- 230V 50Hz 1ph 3.1kW (B232)

### Dimensions:

- 2100(h) x 1220(d) x 800(w) mm load frame
- 2100(h) x 1800(d) x 800(w) mm with temperature controlled cabinet

### Weight:

- 430 kg approx. load frame
- 650 kg approx. load frame with temperature controlled cabinet and oil-filled HPS

## TECHNICAL FEATURES

- **The DTS-30 fatigue rated, servo-hydraulic actuator utilizes metal labyrinth bearings and seals.**  
The labyrinth bearings and seals are designed to reduce friction and maintain low operating temperatures. The bearings experience little-to-no wear, operate at high speeds and offer a long service life.
- **A bottom loading machine.** Before this current crop of universal testing machines, many dynamic testing machines were bottom loading. More recently, the Asphalt Mixture Performance Tester (AMPT) changed the mindset of the testing community by highlighting the benefits of a bottom loading machine.
- **Portable temperature control unit.** The temperature control unit attaches to the test chamber using a magnetic seal and can be wheeled away when not required or for servicing. It can be removed without dismantling the machine or disrupting the testing program.

## NEEDED ACCESSORIES

- B232** Temperature controlled cabinet:  
-40 °C to +80 °C to suit DTS-30 or DTS-130
- B233** Temperature controlled cabinet:  
-50 °C to +100 °C to suit DTS-30 or DTS-130
- B234** Temperature controlled cabinet:  
-50 °C to +80 °C to suit DTS-30 or DTS-130

These temperature controlled cabinets may be supplied with humidity control, if required.

## RECOMMENDED ACCESSORIES

- H009-01EN** PC complete with LCD monitor 22", keyboard, mouse, cables and installation of Testlab software
- B250-07 KIT** Temperature measuring kit comprising:
  - **B292-01N** Temperature transducer (-80 °C to +80 °C) (2 pieces)
  - **B250-10** Dummy asphalt specimen
  - **B250-11** 100 mm O ring (3 pieces)
  - **B250-12** Thermal conducting grease (about 56 g)

We can upgrade your existing UTM (also from other manufacturers)

For test configurations and related jigs, please consult p. 36-47

### Can't see the Control and Data Acquisition System (CDAS2)? That's because it's housed neatly, in the cabinet in front of the machine.

You won't see a tangle of cables either; they enter the cabinet through the floor of the test chamber or through the back of the cabinet and connect to the CDAS2.

The door of the cabinet can be held ajar to allow transducers to be re-allocated or opened completely for servicing. Unused transducers can also be stored out of harm's way.

Moreover, the DTS-30 reaction frame is symmetrical; **the servo-hydraulic actuator and reaction shaft can be interchanged to make the DTS-30 top loading.**



CDAS2

## WHAT MAKES IT DIFFERENT MAKES IT BETTER!

The DTS-30 is Universal Testing Machine (UTM), but not as most people know it. **It does not conform to the “me too” attitude of most UTM manufacturers.** The innovations featured on the DTS-30 are built on many years of experience, developing, studying and using various universal testing machines from a number of manufacturers.

The first thing you will notice about the DTS-30 is the absence of a reaction frame. **The reaction frame** most certainly exists, but it's **embedded in the test chamber.**

Since it is mandatory to control the test temperature of most pavement materials, e.g. asphalt, **the test chamber is insulated and forms part of the temperature controlled cabinet.**

Most UTM manufacturers opt for an elaborate (and expensive) moveable crosshead, only to find that its range (and usefulness) is limited by the climatic chamber. The DTS-30 has a remotely positioned reaction shaft that adjusts the work space. However, you won't need to adjust it often because the **servo-hydraulic actuator has 100 mm of stroke.**



**B230** DTS-30 Dynamic Testing System, detail



Portable temperature control unit



### DYNAFLO™ HPS

The speed of the pump motor is controlled using a **variable-frequency drive (VFD), or inverter.** This enables the motor to be slowed down, or turned off, when the oil flow from the pump exceeds the flow required by the actuator at any given time.



### QUIET

The servo-hydraulic testing machine is almost **silent during the majority of test applications.** The equipped Dynaflo-HPS not only reduces noise and heat generation but also offers cost savings, by reducing power consumption.



### DESIGN SOLUTION

A neat, compact and integrated solution where the **reaction frame is embedded** in the test chamber, for a very sleek appearance. Moreover, short hydraulic hoses connect the actuator to the HPS that's tucked neatly away behind the machine, under the test chamber.



### EASY MAINTENANCE

The **portable temperature control unit** makes servicing, replacing or upgrading the control unit virtually effortless.



### DIRECT COMMUNICATION

The test temperature and/or ramp rate may be set and monitored through TestLab software, via the virtual pendant.

## B240 130 kN SERVO-HYDRAULIC DYNAMIC TESTING SYSTEM (DTS-130)

The DTS-130 Dynamic Testing System is a servo-hydraulic testing machine utilizing digital control of a high performance servo valve to provide accurate loading wave shapes up to 100 Hz. The DTS-130 is Pavetest's highest capacity Dynamic Testing System and completes the range of standard universal testing machines. The system can be operated in tension, compression dynamic loading and is suited to testing a diverse range of engineering materials and/or large asphalt specimens at very cold temperatures.

The DTS-130 is underpinned by Pavetest's leading edge CDAS2 digital controller, TestLab software and a full complement of accessories, hardware and software in perfect unison.

### MAIN FEATURES

- Robust two column load frame.
- Double acting servo hydraulic, equal area type with low friction, long life bearings and seals.
- Portable temperature control unit.
- Fully configurable to suit a large range of testing applications.
- Digital Servo-Hydraulic control.
- Dynaflo™ HPS variable frequency drive (VFD) provides dynamic speed control of the pump motor ensuring quiet operation.
- 4 axis control and 16 channel data acquisition as standard.

The machine includes:

- Rigid two column load frame
- 130 kN Servo-hydraulic actuator (100 mm Stroke)
- 10 kW Hydraulic Power Supply
- 16 Channel Control and Data Acquisition System (CDAS2) & TestLab software
- Load cell ( $\pm 130$  kN)
- 100 mm actuator LVDT

### B240L

Same as B240 but with different frame dimensions:  
3000(h) x 1070(d) x 1237(w) mm load frame.

3000(h) x 1630(d) x 1237(w) mm with temperature controlled cabinet.

780 kg approx. load frame.



### B240

130 kN Servo-Hydraulic Dynamic Testing System  
with **B232** temperature controlled cabinet

## TECHNICAL SPECIFICATIONS

### Load frame:

- Horizontal Space: 60 cm
- Vertical Space: 100 cm

### Servo actuator:

- Capacity:  $\pm 130\text{kN}$  Static  $\pm 100\text{kN}$  Dynamic
- Frequency: Up to 100Hz
- Stroke: 100 mm

### Hydraulic Power Supply:

- Pressure: Up to 210 bar, user defined
- Flow rate: 20 litres/min
- Dimensions: 1150 (h) x 600 (d) x 1100 (w) mm
- Power supply: 380V 50Hz or 208V 60Hz 12kW 3ph

### Power Supply:

- 380V 50Hz 3ph + neutral 12kW or
- 208V 60Hz 3ph + 12kW (B240)
- 230V 50Hz 1ph 3.1kW (B232)

### Dimensions:

- 3005 (h) x 1070 (d) x 1090 (w) mm load frame
- 3005 (h) x 1630 (d) x 1090 (w) mm with temperature controlled cabinet

### Weight:

- 680 kg approx. load frame
- 1360 kg approx. load frame with temperature controlled cabinet and oil-filled HPS



**B240** 130 kN Servo-Hydraulic Dynamic Testing System with **H009-01EN** complete PC, **B232** Temperature controlled cabinet, **B240-03** Exchanger oil/water, HPS (hydraulic power supply)

ACCESSORIES		B240-02 Exchanger oil/air	B240-03 Exchanger oil/water *
<b>B240-04</b>	Chiller for water refrigeration (recommended)		▼
<b>B240-05</b> or <b>B240-06</b>	Set of hoses to connect frame - pumping unit Lg. 3 m (needed) Set of hoses to connect frame - pumping unit Lg. 8 m (needed)	▼ ▼	▼ ▼
<b>B240-07</b> or <b>B240-08</b>	Set of hoses to connect pumping unit - Exchanger oil/air Lg. 5 m (needed) Set of hoses to connect pumping unit - Exchanger oil/air Lg. 10 m (needed)	▼ ▼	
<b>B240-09</b> or <b>B240-10</b>	Set of hoses to connect Exchanger oil/water - Chiller Lg. 5 m (recommended) Set of hoses to connect Exchanger oil/water - Chiller Lg. 10 m (recommended)		▼ ▼

\* (complete with set of hoses to connect pumping unit Exchanger oil/water)

The **Hydraulic Power Supply (HPS)** utilizes a variable flow pump with a working pressure up to 210 Bar. The customer can choose either water (heat exchanger) or air (Electric fan) oil cooling. Features include; low oil, over temperature and dirty filter indication, remote starting and user selectable working pressure (via TestLab).

**B232** Temperature controlled cabinet:  
-40 °C to +80 °C to suit DTS-30 or DTS-130

**B233** Temperature controlled cabinet:  
-50 °C to +100 °C to suit DTS-30 or DTS-130

**B234** Temperature controlled cabinet:  
-50 °C to +80 °C to suit DTS-30 or DTS-130

## RECOMMENDED ACCESSORIES

- H009-01EN** PC complete with LCD monitor 22", keyboard, mouse, cables and installation of Testlab software
- B250-07 KIT** Temperature measuring kit (refer to p. 29)

These temperature controlled cabinets may be supplied with humidity control, if required.

We can upgrade your existing UTM (also from other manufacturers)

For test configurations and related jigs, please consult p. 36-47

## TWO PIECE TEMPERATURE CONTROLLED CABINET

Pavetest offers a range of temperature controlled cabinet to complement our **DTS-30** and **DTS-130** servo-hydraulic Dynamic Testing Systems (DTS). **Pavetest is the first manufacturer to adopt a two piece temperature controlled cabinet**; comprising an insulate cabinet and a temperature control unit. The cabinet is permanently mounted on the dynamic testing machines, whilst the temperature control unit can be wheeled away when not required, leaving the back of the chamber open to accommodate longer jigs/specimens that do not require a controlled environment. The temperature control unit attaches to the cabinet using a magnetic seal. This isolates the cabinet from mechanical vibrations caused by the refrigeration unit and circulation fans whilst maintaining an air tight seal between the inside and outside of the chamber. This concept also makes servicing, replacing or upgrading the temperature control unit virtually effortless, because it can be removed with-out dismantling the machine or disrupting the testing program.

### MAIN FEATURES

- Two piece concept makes servicing, replacing or upgrading the temperature control unit effortless.
- Flexible temperature sensor ensures the temperature near the specimen is accurately controlled.
- Operator can monitor, set, adjust or “Auto tune” the temperature controller via the PC.
- Heavy duty stainless steel construction.
- Powerful re-circulation fans ensure even temperature through-out the chamber.
- Triple Glazed, Argon filled, Lo E glass door with built in heater.



Two piece temperature controlled cabinet

## B250 KIT Indirect Tensile Modulus - IDTM

STANDARDS: AASHTO TP31 Resilient modulus of bituminous mixtures by indirect tension  
 ASTM D4123 Indirect Tension Test for Resilient Modulus of Bituminous Mixtures  
 AS/NZS 2891.13.1 Resilient modulus of asphalt - Indirect tensile method  
 EN 12697-26 Annex C - Indirect tension to cylindrical specimens (IT-CY)  
 EN 12697-26 Annex F - Cyclic indirect tension to cylindrical specimens (CIT-CY)



### TEST FRAMES

Manual DTS-16 | Motorized DTS-16 (B221)  
 DTS-30 | DTS-130 (B232 or B234) | SmartPulse (B265)

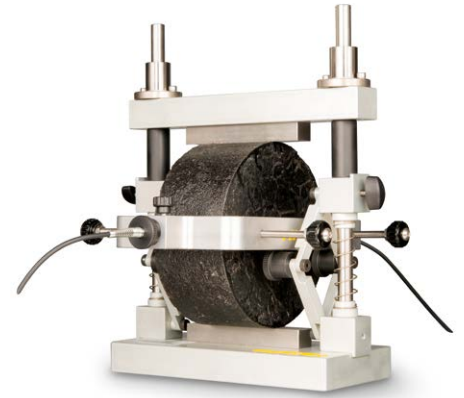

### B250 KIT Indirect Tensile Modulus

Comprises:

- B250-01** Basic IDT Jig
- B250-08** Yoke
- B250-09** Assembly for B250 KIT
- B290-01N** LVDT (0.2 mm) (2 pieces)

### ACCESSORIES

- B250-03** Asphalt proving ring
- B250-04** 100 mm diameter PVC specimen
- B250-05** 150 mm diameter PVC specimen
- B250-06 KIT** Torque screwdriver (B250-13) with hexagonal head 4 mm (B250-14)

## B251 KIT Indirect Tensile Fatigue - IDTF

STANDARD: EN 12697-24 Annex E – Indirect tensile test on cylindrical shaped specimens



### TEST FRAMES

Manual DTS-16 | Motorized DTS-16 (B221)  
 DTS-30 | DTS-130 (B232 or B234) | SmartPulse (B265)

**Note:** B252 KIT, combines B250 KIT with B251 KIT, and allows users to perform both IDTM and IDTF tests.



### B251 KIT Indirect Tensile Fatigue

Comprises:

- B250-01** Basic IDT Jig
- B290-03N** LVDT, double ball ended (3.75 mm) (2 pieces)
- B251-01** LVDT mounting strip gluing jig

### ACCESSORIES

- B251-51** Pair of LVDT mounting strip to suit 100 mm specimen (**needed** accessory)

And/or

- B251-52** Pair of LVDT mounting strip to suit 150 mm specimen (**needed** accessory)
- B201-52** 5 Minute, two part epoxy 24 ml

## B260 KIT Uniaxial cyclic compression - UCC

STANDARD: EN 12697-25 Cyclic compression. Test Method A - Uniaxial cyclic compression test with confinement  
TP Asphalt-StB 25A1: Dynamic punching test on mastic asphalt  
TP Asphalt-StB 25A2: Dynamic punching test on rolled asphalt



### B260 KIT Uniaxial cyclic compression

Comprises:

- B260-01N** Base assembly
- B260-02** Chamfered top platen
- B290-02N** LVDT (10 mm) (2 pieces)

### TEST FRAMES

Manual DTS-16 | Motorized DTS-16 (B221)  
DTS-30 | DTS-130 (B232 or B234) | SmartPulse (B265)

### ACCESSORY

- B260-05** Upper loading platen in accordance with method A2 EN 12697-25
- B260-06** 56.4 mm top loading platen for TP Asphalt-STB Part 25A1
- B260-07** 80 mm top loading platen for TP Asphalt-STB Part 25A2

## B260-10 PULL OFF TENSION JIG

STANDARD: TP Asphalt-StB – Part 81, Adhesive pull strength of thin asphalt layers

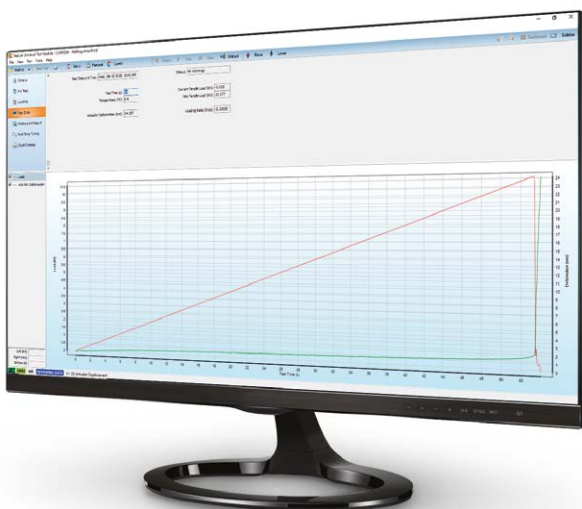

**B260-10** Pull off tension jig

### TEST FRAMES

DTS-30 (B232 or B234)

### ACCESSORY

- B261-01** DTS-30 Tension base (needed)

## B253 KIT

### Indirect Tensile modulus, creep compliance and strength using on-specimen transducers - IDTOS

STANDARDS: ASTM D7369 Resilient Modulus of Bituminous Mixtures by Indirect Tension Test  
 AASHTO T322 Creep Compliance and Strength of Hot-Mix Asphalt (HMA)  
 Using the Indirect Tensile Test Device



#### TEST FRAMES

Manual DTS-16 | Motorized DTS-16 (B221)  
 DTS-30 | DTS-130 (B232 or B234) | SmartPulse (B265)



**B253 KIT** Indirect Tensile modulus, creep compliance and strength using on-specimen transducers

Comprises:

- B250-01** Basic IDT Jig
- B253-01** AASHTO T322 LVDT mounting Jig
- B290-04N** Miniature LVDT (1 mm) (4 pieces)
- B253-02** AASHTO T322 gauge point template (100 mm specimen)
- B253-03** AASHTO T322 gauge point template (150 mm specimen)

#### ACCESSORIES

- B253-53** Gauge point (24 **needed** pieces)
- B201-52** 5 Minute, two part epoxy 24 ml
- B230-05** Force intensifier, designed specifically for DTS-30. It enables 30 kN machine to perform tests that require more than 100 kN static load, in order to meet also AASHTO T322.

## B212

### Four Point Bending - 4PB

STANDARDS: AASHTO T321 Fatigue Life of Compacted Hot-Mix Asphalt (HMA) Subjected to Repeated Flexural Bending  
 ASTM D7460 Fatigue Failure of Compacted Asphalt Concrete Subjected to Repeated Flexural Bending  
 AG:PT/T233 Fatigue life of compacted bituminous mixes subject to repeated flexural bending  
 AG:PT/T274 Characterisation of flexural stiffness and fatigue performance bituminous mixes  
 EN 12697-24 Annex D - Four point bending test on prismatic shaped specimens  
 EN 12697-26 Annex B - Four point bending test on prismatic specimens (4PB-PR)

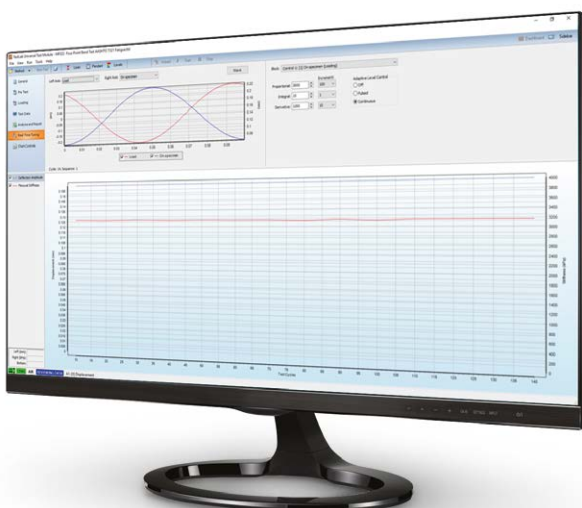

#### TEST FRAMES

DTS-30 (B232 or B234) | SmartPulse (B265)

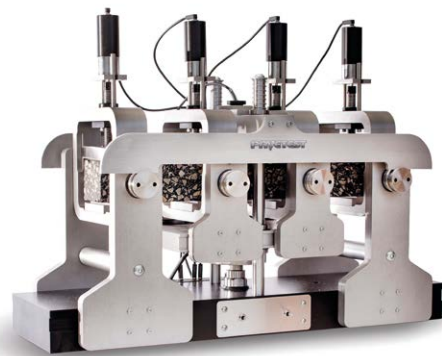

#### ACCESSORIES

- B210-02** 4PB PVC Beam
- B210-03** 4PB Reference beam

## B256 KIT Ideal RT

STANDARD: ASTM D8360-22 Standard Method for Determination of Rutting Tolerance Index of Asphalt Mixture Using the Ideal Rutting Test

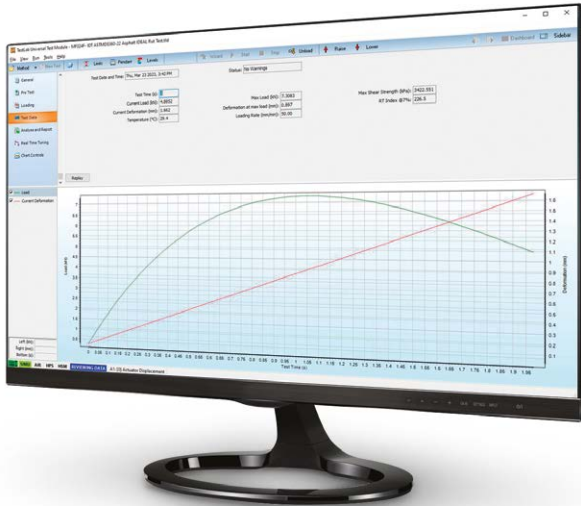

### TEST FRAMES

Manual DTS-16 | Motorized DTS-16 (B221)  
DTS-30 | DTS-130 (B232 or B234) | SmartPulse (B265)

### B256 KIT Ideal RT

Comprises:

- B256-01** Ideal RT Jig
- B250-01** Basic IDT Jig



## B257 KIT Ideal CT

STANDARD: ASTM 8225 Indirect Tensile Asphalt Cracking Test

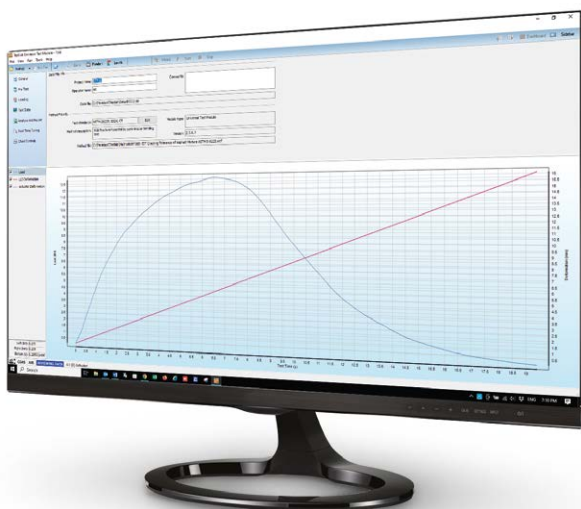

### TEST FRAMES

DTS-30 (B232) | DTS-130 (B240)

### Ideal CT

Comprises:

- B253** Indirect tensile modulus, creep compliance and strength using on-specimen transducers
- B253-06** Loading Strips



 **Note:** It is possible to perform Ideal CT also with B250-01 Jig

## B280 KIT

### TWO POINT BENDING (2PB) TO SUIT B230 - 2PB

STANDARDS: EN 12697-24 Annex A - Two-point bending test on trapezoidal shaped specimens (2PB-TR)  
 EN 12697-26 Annex A - Two point bending test on trapezoidal specimens (2PB-TR)

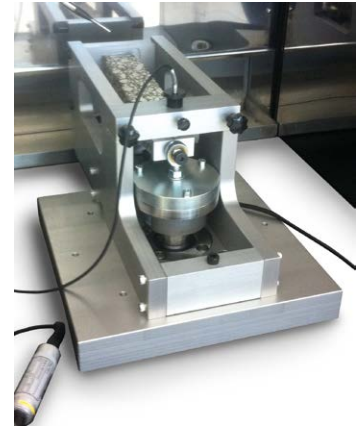
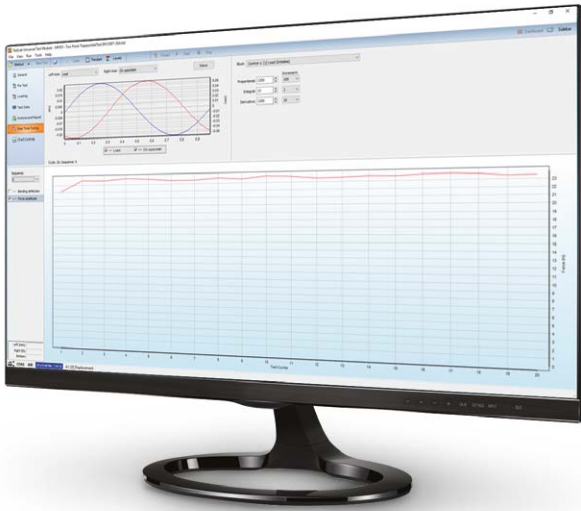

**B280 KIT** Two Point Bending (2PB) to suit B230.  
 Comprises:

- B280-01** 2PB Jig
- B280-51** 2PB Mounting plate (25 mm apex)
- B280-52** 2PB Mounting plate (50 mm apex)
- B280-53** 2PB Mounting plate (base)

### TEST FRAMES

DTS-30 (B232 or B234) | SmartPulse (B265)

### ACCESSORIES

- B290-05N** LVDT (2 mm) (**needed** accessory)
- B280-02** Two point Bending (2PB) gluing jig (**needed** accessory)
- B201-52** 5 Minute, two part epoxy 24 ml

## B261 KIT

### Permanent deformation - PD

STANDARD: AS/NZS 2891.12.1 Determination of the permanent compressive strain characteristics of asphalt - Dynamic creep test  
 TP Asphalt-StB – Part 25B Uniaxial pressure-fatigue testing. Determination of deformation behavior of roller asphalt during heat



**B261 KIT** Permanent deformation  
 Comprises:

- B260-01N** Base assembly
- B260-03** 100 mm top platen
- B290-02N** LVDT (10 mm) (2 pieces)

### TEST FRAMES

Manual DTS-16 | Motorized DTS-16 (B221)  
 DTS-30 | DTS-130 (B232 or B234) | SmartPulse (B265)

### ACCESSORY

- B260-04** 150 mm top platen

## B255 KIT Dynamic modulus - E\*

STANDARD: AASHTO T342 Determining Dynamic Modulus of Hot Mix Asphalt (HMA)

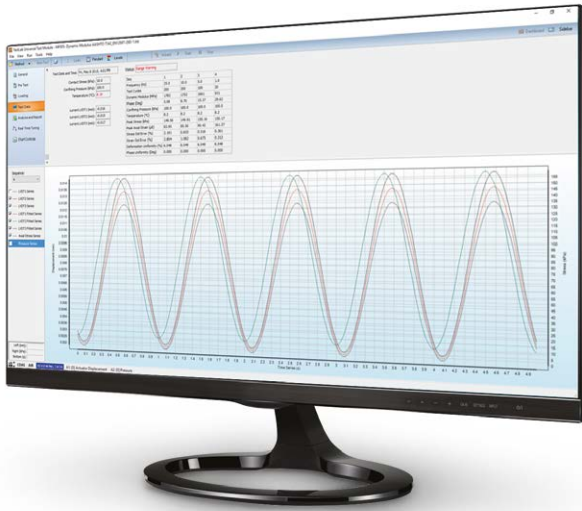

### B255 KIT Dynamic modulus

Comprises:

- B200-02** 105 mm bottom loading platen
- B200-03** 105 mm top loading platen
- B253-04** AASHTO T342 LVDT mounting jig (3 pieces)
- B290-06N** LVDT (1 mm) (3 pieces)
- B253-05** Screwdriver hex bit with spherical head size 2 mm

### TEST FRAMES

DTS-30 | DTS-130 (B232 or B234) | SmartPulse (B265)

### ACCESSORIES

- B202** Gauge Point Fixing Jig
- B203** Dynamic Verification Device
- B253-53** Gauge point (24 **needed** pieces)
- B201-52** 5 Minute, two part epoxy 24 ml

### DYNAMIC MODULUS ON SMALL SPECIMENS | DTS-30/130

To test 38 mm (diameter) x 110 mm (h) specimens with DTS-30/130, the following items are required

- B200-05** Bottom loading platen for 38 x 110 mm ( $\emptyset$  x h) specimen
- B200-06** Top loading platen for 38 x 110 mm ( $\emptyset$  x h) specimen
- B253-04** AASHTO T342 LVDT mounting jig (3 pieces)
- B290-06N** LVDT (1 mm) (3 pieces)
- B253-53** Gauge point (24 needed pieces)
- B253-05** Screwdriver hex bit with spherical head size 2 mm
- B202** Gauge Point Fixing Jig
- B202-02** Spacer for 110 mm specimen height to be used with gauge point fixing jig B202
- B202-03** 38 mm and 50 mm diameter specimen - extension for gauge point fixing jig plungers B202
- B203** Dynamic Verification Device (optional)
- B201-52** 5 Minute, two part epoxy 24 ml (optional)

To test 50 mm (diameter) x 135 mm (h) specimens with DTS-30/130, the following items are required:

- B200-07** Bottom loading platen for 50 x 135 mm ( $\emptyset$  x h) specimen
- B200-08** Top loading platen for 50 x 135 mm ( $\emptyset$  x h) specimen
- B253-04** AASHTO T342 LVDT mounting jig (3 pieces)
- B290-06N** LVDT (1 mm) (3 pieces)
- B253-53** Gauge point (24 needed pieces)
- B253-05** Screwdriver hex bit with spherical head size 2 mm
- B202** Gauge Point Fixing Jig
- B202-01** Spacer for 135 mm specimen height to be used with gauge point fixing jig B202
- B202-03** 38 mm and 50 mm diameter specimen - extension for gauge point fixing jig plungers B202
- B203** Dynamic Verification Device (optional)
- B201-52** 5 Minute, two part epoxy 24 ml (optional)

## B271 KIT

### Cyclic triaxial compression - CCT

STANDARD: EN 12697-25 Cyclic compression. Test Method B - Triaxial cyclic ompression test



#### TEST FRAMES

Manual DTS-16 | Motorized DTS-16 (B221)  
 DTS-30 | DTS-130 (B232 or B234 | SmartPulse (B265)

**B271 KIT** Cyclic triaxial compression  
 Comprises:

- B270-01** Triaxial cell, suitable for  $\varnothing$  100 mm, up to 200 mm height specimens
- B270-02** Triaxial cell external LVDT mounting jig
- B293-01N** Pressure transducer ( $\pm$  300 kPa)
- B270-06** 110 mm diameter top loading platen for EN 12697-25B
- B270-15** 110 mm diameter base pedestal for 100 mm height specimen



#### ACCESSORIES

- B290-02N** Displacement transducer (10 mm) (2 pieces **needed**)
  - B270-04** Air reservoir assembly confining pressure upgrade kit (**needed** accessory for DTS-16)
- or
- B270-03** Air reservoir assembly with confining pressure control (**needed** accessory for DTS-30/130)
  - B270-17**  $\varnothing$  200 mm base plate (**needed** accessory for DTS-30)
  - B270-18** Membrane stretcher for asphalt specimen  $\varnothing$  100 mm
  - B201-53**  $\varnothing$  100 mm rubber membrane 0.3 mm thickness (pack of 10)
  - S311-03**  $\varnothing$  100 mm sealing ring (10 pieces)
  - S316-03**  $\varnothing$  100 mm porous disc (2 pieces) needed for AASHTO T307  
 Requires pressurized air, minimum 7 bar (not included)

## B272 KIT

### Triaxial resilient modulus - TRM

STANDARD: AASHTO T307 Determining the resilient modulus of soils and aggregate materials

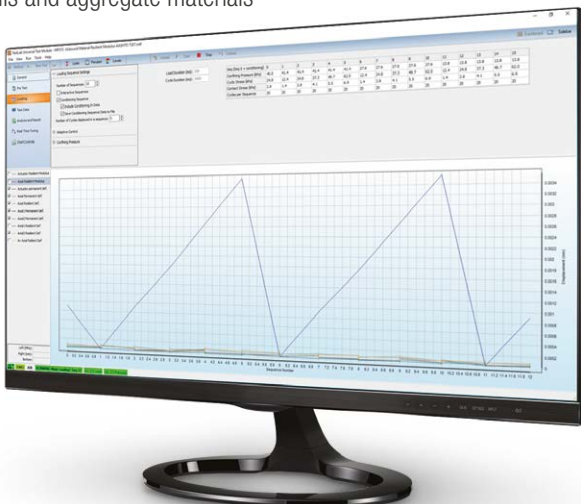

#### TEST FRAMES

Manual DTS-16 | Motorized DTS-16  
 DTS-30 | DTS-130 | SmartPulse (B265)

**B272 KIT** Triaxial resilient modulus  
 Comprises:

- B270-01** Triaxial cell, suitable for  $\varnothing$  100 mm, up to 200 mm height specimens
- B270-02** Triaxial cell external LVDT mounting jig
- B293-02N** Pressure transducer ( $\pm$  600 kPa)
- S315-07** 100 mm diameter bottom platen
- S314-03** 100 mm diameter top platen

To test 150x300 mm samples B276-KIT is required. It comprises:

- B272 KIT** as described above, plus:
- S306-10** Triaxial cell extension to accommodate up to 300 mm tall specimens
- B270-10** 150 mm diameter x 300 mm bottom platen assembly for AASHTO T307/TP46
- B270-11** 150 mm diameter top platen for AASHTO T307/TP46



#### ACCESSORIES

Same accessories of B271 KIT

## B274-KIT Triaxial testing kit

STANDARDS: AASHTO T378 Standard Method of Test for Determining the Dynamic Modulus and Flow Number for Asphalt Mixtures



### TEST FRAMES

Manual DTS-16 | Motorized DTS-16 (B221)  
DTS-30 | DTS-130 (B232 or B234) | SmartPulse (B265)

### B274 KIT Triaxial testing Kit

Comprises:

- B270-01** Triaxial cell, suitable for  $\varnothing$  100 mm x up to 200 mm tall
- B293-01N** Pressure transducer ( $\pm$  300kpa)
- B200-03** 105 mm top loading platen
- B270-16**  $\varnothing$  105 mm base pedestal for 150 mm height specimen



### ACCESSORIES

- B200-01N** AMPT LVDT 2.00 mm (3 needed)
  - B270-04** Air reservoir assembly confining pressure upgrade jig (needed for DTS-16)
- or
- B270-03** Air reservoir assembly with confining pressure control (needed for DTS-30/130)
  - B270-17**  $\varnothing$  200 mm base plate (**needed** accessory for DTS-30)
  - B253-53** Gauge point (24 pieces needed)
  - B201-52** 5 minute, two part epoxy 24 ml
  - S311-03** Sealing ring  $\varnothing$  100 mm
  - B201-53** 100 mm rubber membrane 0.3 mm thickness (pack of 10)
  - B202** Gauge point fixing jig
  - B203** AMPT dynamic verification device
  - B200-10** Latex membrane material cut in  $\varnothing$  100 mm discs (needed for AASHTO T378)

Requires pressurized air, minimum 7 bar (not included)

## B254 KIT Semi-Circular Bending - SCB

STANDARD: EN 12697-44 Tensile Strength and Fracture Toughness-Crack Propagation

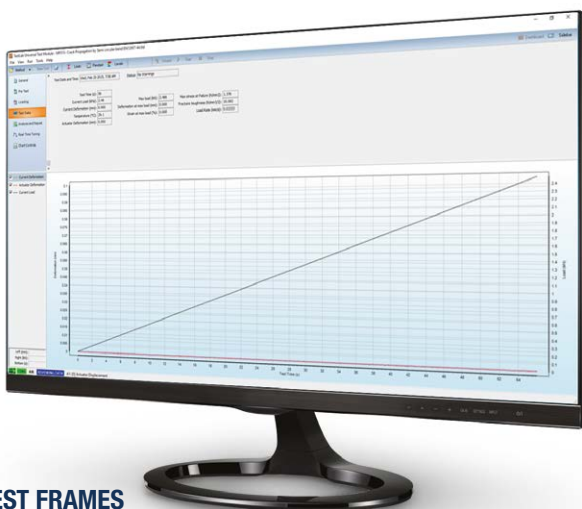

### TEST FRAMES

Manual DTS-16 | Motorized DTS-16 (B221)  
DTS-30 | DTS-130 (B232 or B234) | SmartPulse (B265)

### B254 KIT EN SCB testing kit

Comprises:

- B254-01** SCB jig
- B254-51** Pair of SCB wear plates



### ACCESSORIES

- B250-01** Basic Indirect Tensile Jig (**needed** accessory)
- B290-07N** Deformation gauge
- B290-02N** Displacement transducer (10 mm) (2 optional pieces)

## B254-02 KIT AASHTO | ASTM SCB testing kit

STANDARDS: AASHTO T393 (Method B) Determining the fracture potential of asphalt mixtures using semicircular bend geometry (SCB) at intermediate temperature  
 ASTM D8044 Evaluation of asphalt mixture cracking resistance using the semi-circular bend test (SCB) at intermediate temperature  
 AASHTO T394 Determining the fracture energy of asphalt mixtures using the semicircular bend geometry (SCB)



### TEST FRAMES

DTS-30 | DTS-130 (B232 or B234) | SmartPulse (B265)

### B254-02 KIT AASHTO | ASTM SCB testing kit

Comprises:

- B208** SCB frame
- B254-10** Roller support
- B254-02** Springs and roller



### OPTIONAL ACCESSORIES for AASHTO T393, ASTM D8044

- B290-02N** LVDT (10mm) (1 or 2)
- B254-11** LVDT mounting assembly (q,ty according to B290-02N)
- B254-12** Positioning device
- B254-03** Upgrade for AASHTO TP124 Method A

### NEEDED ACCESSORIES for AASHTO T394

- B254-13** Gauge point template
- B254-14** LVDT mounting hardware (2 **needed**)
- B254-15** LVDT mounting frame (2 **needed**)
- B253-53** Gauge point (2 **needed**)
- B290-05N** LVDT 2.00 mm (2 **needed**) or  
**B290-06N** LVDT 1.00 mm (2 **needed**)
- B290-07N** SCB deformation gauge or  
**B290-16N** Epsilon (model 3541) clip-on gauge CMOD transducer -1/+2.5 mm + **C090-18** Knife edge (pack of 24 only for B290-16)

## B282 KIT Thermal Stress Restrained Specimen Test - TSRST

STANDARDS: AASHTO TP10 Thermal Stress Restrained Specimen Tensile Strength  
EN 12697-46 Low Temperature Cracking and Properties by Uniaxial Tension  
TP Asphalt-StB 46A Cold properties: uniaxial tensile stress test and thermal stress restrained specimen test

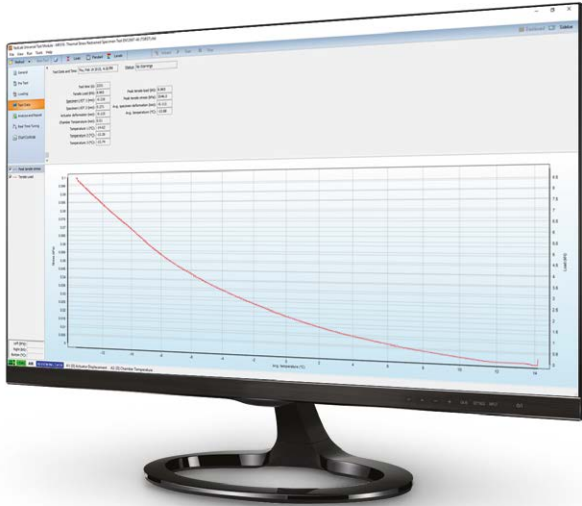

### TEST FRAMES

DTS-30 | DTS-130 (B232 or B234)

**B282 KIT** Thermal Stress Restrained Specimen Test

Comprises:

- B282-01N** TSRST Temp Transducer (-80°C to +80°C) (3 pieces)
- B282-02** Rod End (2 pieces)
- B282-03** Clevis Yoke and Pin (2 pieces)
- B282-04** Platen (2 pieces)
- B282-05** LVDT Holder (2 pieces)
- B282-06** Invar Rod (250 mm long) (2 pieces)
- B282-07** Multi tack adhesive squares

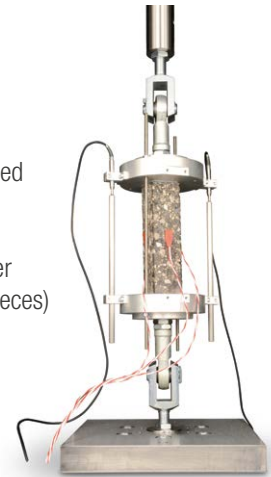

### ACCESSORIES

- B290-09N** Displacement transducer (5 mm) (2 pieces **needed**)
- B261-01** B230 tension base (**needed** accessory for DTS-30)
- B282-08** TSRST specimen gluing jig (1 piece **needed**)
- B201-52** 5 minute, two part epoxy 24 ml

## B284-01 Disk Shaped Compact Tension Test Kit - DC(T)

STANDARD: ASTM D7313-07a Determining fracture energy of asphalt aggregate mixtures using the disk-shaped compact tension geometry



### TEST FRAMES

DTS-30 | DTS-130 (B232 or or B234) | SmartPulse (B265)

**B284-01** Disk Shaped Compact Tension Test Kit



### ACCESSORIES

- B261-01** B230 tension base (**needed** accessory for DTS-30)
- B290-07N** Deformation gauge (**needed** accessory)
- or
- B290-12N** Epsilon Clip-On gauge 12.5 mm +1/-7 mm (**needed** accessory)
- C090-18** Knife edge (Pack of 24) only for B290-12N

## B264 KIT Direct tension testing kit - DTT

STANDARDS: EN 12697-26 Annex E - Test applying direct tension to cylindrical specimens (DT-CY) or to prismatic specimens (DT-PR)  
 EN 12697-26 Annex D - Direct tension-compression test on cylindrical specimens (DTC-CY)  
 AASHTO TP 107-14 Standard Method of Test for Determining the Damage Characteristic Curve of Asphalt Mixtures from Direct Tension Cyclic Fatigue Tests

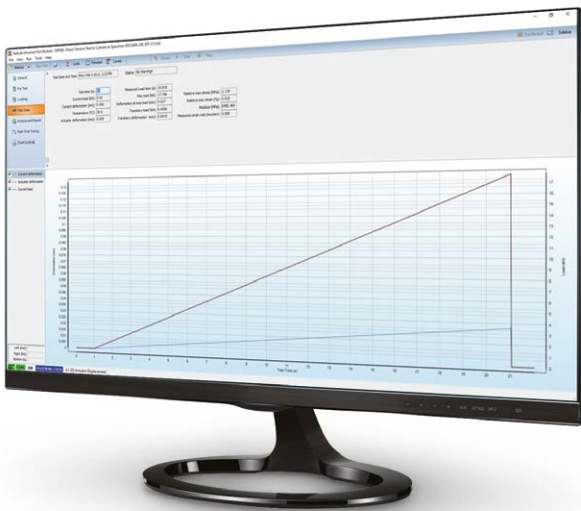

### TEST FRAMES

DTS-30 | DTS-130 (B232) | SmartPulse (B265)



### B264 KIT Direct tension testing kit

Comprises:

- B261-02** Spherical seat coupling (2 pieces)
- B261-03** 100 mm tension platen (2 pieces)

### ACCESSORIES

- B253-04** LVDT mounting (3 pieces **needed**) jig
- B290-06N** LVDT (1 mm) (3 pieces **needed**)
- B253-05** Screwdriver hex bit with spherical head size 2 mm
- B201-52** 5 Minute, two part epoxy 24 ml
- B202** Gauge point fixing jig
- B202-04** Spacer for 130 mm specimen height to be used with B202 (optional)
- B253-53** Gauge Point (24 pieces)
- B261-01** B230 tension base (**needed** accessory for DTS-30)

### AASHTO TP 107-14 ON SMALL SPECIMENS | DTS-30/130

To test 38 mm (diameter) x 110 mm (h) specimens with DTS-30/130 unit, the following items are required:

- B200-11** 38MM AMPT tension platen (2 pieces needed)
- B261-02** Spherical seat coupling
- B202** Gauge Point Fixing Jig
- B202-02** Spacer for 110 mm specimen height to be used with gauge point fixing jig B202
- B202-03** 38 mm and 50 mm diameter specimen - extension for gauge point fixing jig plungers B202
- B253-04** LVDT mounting (3 pieces needed) jig
- B290-06N** LVDT (1 mm) (3 pieces needed)
- B253-05** Screwdriver hex bit with spherical head size 2 mm
- B201-52** 5 Minute, two part epoxy 24 ml
- B253-53** Gauge Point (24 pieces)

To test 50 mm (diameter) x 135 mm (h) specimens with DTS-30/130 unit, the following items are required:

- B200-12** 50MM AMPT tension platen (2 pieces needed)
- B261-02** Spherical seat coupling
- B202** Gauge Point Fixing Jig
- B202-01** Spacer for 135 mm specimen height to be used with gauge point fixing jig B202
- B202-03** 38 mm and 50 mm diameter specimen - extension for gauge point fixing jig plungers B202
- B253-04** LVDT mounting jig (3 pieces needed)
- B290-06N** LVDT (1 mm) (3 pieces needed)
- B253-05** Screwdriver hex bit with spherical head size 2 mm
- B201-52** 5 Minute, two part epoxy 24 ml
- B253-53** Gauge Point (24 pieces)

## B204 KIT Overlay kit according to ASTM WK26816

STANDARD: ASTM WK26816 New Test Method for Determining the Susceptibility of Asphalt Mixtures to Cracking

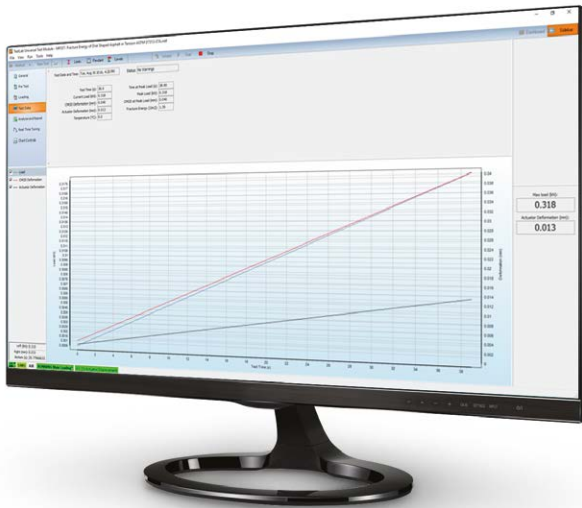

### TEST FRAMES

Manual DTS-16 | Motorized DTS-16 (B221)  
DTS-30 | DTS-130 (B232) | SmartPulse (B265)

## B204-01 KIT Overlay kit according to TEX-248-F

STANDARD: TxDOT Designation. TEX-248-F Test Procedure for Overlay Test

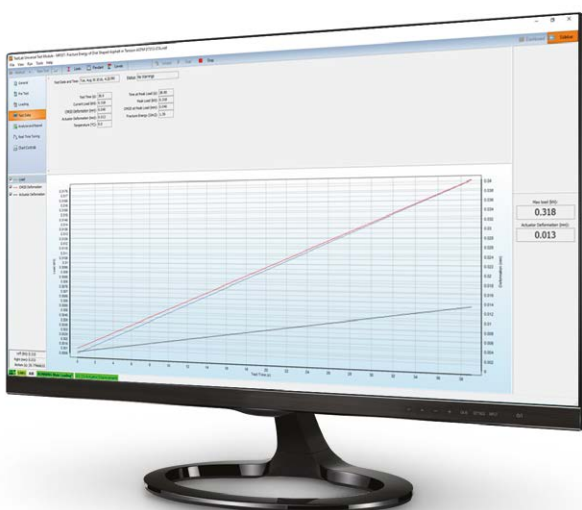

### TEST FRAMES

Manual DTS-16 | Motorized DTS-16 (B221)  
DTS-30 | DTS-130 (B232) | SmartPulse (B265)



### B204 KIT Overlay kit according to ASTM WK26816

Comprises:

**B204-01** Overlay jig

**B204-02** Pair of overlay tester (OT) specimen plates

**B204-03** OT specimen preparation jig according to ASTM WK26816

### NEEDED ACCESSORIES

**B261-01** DTS-30 tension base

**B261-02** Spherical seat coupling

**B290-05N** LVDT 2.00 mm or **B290-06N** LVDT 1.00 mm



### B204-01 KIT Overlay kit according to TEX-248-F

Comprises:

**B204-01** Overlay jig

**B204-02** Pair of overlay tester (OT) specimen plates

**B204-13** OT specimen preparation jig according to TEX-248-F

### NEEDED ACCESSORIES

**B261-01** DTS-30 tension base

**B261-02** Spherical seat coupling

**B290-05N** LVDT 2.00 mm or **B290-06N** LVDT 1.00 mm

## B210 KIT STAND-ALONE SERVO-PNEUMATIC FOUR POINT BENDING (4PB) SYSTEM

STANDARDS: EN 12697-24 Annex D | EN 12697-26 Annex B | AASHTO T321 | ASTM 03 | ASTM-D7460

The Pavetest Servo-pneumatic Four Point Bending (4PB) System is a servo-pneumatic testing machine utilizing digital control of a high performance servo valve to provide accurate loading wave shapes up to 60Hz. The 4PB system can be operated in haversine or sinusoidal, controlled strain or sinusoidal controlled stress mode to determine the flexural stiffness/modulus and resistance to fatigue of asphalt beams of various sizes.

### MAIN FEATURES

- Robust four point loading frame.
- Backlash free rotation and translation on all load and reaction points.
- Fully configurable to suit a large range of testing applications.
- High performance servo-valve.
- Long life pneumatic actuator.
- Digital Servo-pneumatic control.
- 2 axis control and 8 channel data acquisition.



**B210-01**  
 Servo-pneumatic four point apparatus

**B210 KIT** comprises:

- **B210-01** Servo-pneumatic Four Point Bending (4PB) Device with 10 mm actuator LVDT,  $\pm 5$  kN load cell. and 2 mm On-specimen LVDT
- **B209-08** 8 Channel Control and Data Acquisition System (CDAS2) & TestLab software
- **B270-12** Air reservoir assembly with membrane dryer

It requires pressurized air, minimum 7 bar (not included)

The 4PB System is underpinned by Pavetest's leading edge CDAS2 digital controller, TestLab software and a full complement of accessories, hardware and software in perfect unison.

## TECHNICAL SPECIFICATIONS

### Load frame

- Outer clamp span 355.5 mm (14") and 420 mm
- Nominal beam size(s): 50 mm (h) x 50 mm (w)  
50 mm (h) x 63.5 mm (w)  
70 mm (h) x 70 mm (w)  
70 mm (h) x up to 85 mm (w)

### Servo actuator

- Capacity  $\pm 5$  kN
- Frequency Up to 60Hz;
- Stroke 10 mm
- Air supply clean dry air
- Pressure 800-900 kPa
- Minimum rate up to 5 litres/sec

### On-specimen transducer

- Range  $\pm 1$  mm
- Resolution 0.0002  $\mu$ m
- Accuracy Better than 5  $\mu$ m

**Power Supply:** 90-264V 50/60Hz 1ph 240W (B210 KIT)

**Dimensions:** 590(h) x 250(d) x 570(w) mm (B210-01)  
410(h) x 250(d) x 570(w) mm (B212)

**Weight:** 45 kg approx. (B210-01)  
35 kg approx. (B212)

## NEEDED ACCESSORIES

- B210-02** 4PB PVC Beam
- B210-03** 4PB Reference beam
- B250-07 KIT** Temperature measuring kit comprising:
  - **B292-01N** Temperature transducer (-80 °C to +80 °C) (2 pieces)
  - **B250-10** Dummy asphalt specimen
  - **B250-11** 100 mm O ring (3 pieces)
  - **B250-12** Thermal conducting grease (about 56 g)



**B210-02** PVC Beam



**B210-01** Servo-pneumatic four point apparatus, detail

## RECOMMENDED ACCESSORIES

- B221** Temperature controlled cabinet: -30 °C to +70 °C to suit DTS-16 or 4PBA
- H009-01EN** PC complete with LCD monitor 22", keyboard, mouse, cables and installation of Testlab software

### 4PBA sharing CDAS2 with DTS16:

- B210-01** Servo-pneumatic Four Point Bending (4PB) device with 10 mm actuator LVDT,  $\pm 5$  kN load cell and 2 mm Onspecimen LVDT (sharing CDAS2 with DTS 16)

It requires pressurized air (not included).

### 4PBA sharing CDAS2 with DTS130:

- B210-01** Servo-pneumatic Four Point Bending (4PB) device with 10 mm actuator LVDT,  $\pm 5$  kN load cell and 2 mm Onspecimen LVDT (sharing CDAS2 with DTS 130)

- B270-12** Air reservoir assembly with membrane dryer

It requires pressurized air (not included).



**B270-12**  
Air reservoir assembly with membrane dryer

**B200L**
**AMPT (SPT)**
**ASPHALT MIXTURE PERFORMANCE TESTER**

COMPACT, FULLY SELF CONTAINED, PRECISION ENGINEERED UNIT

The Pavetest AMPT is a servo-hydraulically controlled testing machine specifically designed to perform the three asphalt tests developed under NCHRP Projects 9-19 and 9-29; Dynamic Modulus, Flow Number and Flow Time. It is also the prescribed equipment in AASHTO T378 -17 Standard Method Test for Determining the Dynamic Modulus and Flow Number for Hot Mix Asphalt (HMA) using the Asphalt Mixture Performance Tester (AMPT). In addition, the Pavetest AMPT can also perform AASHTO TP107 for Determining the Damage Characteristic Curve and Fatigue Analysis Parameters of Asphalt Mixtures in the AMPT, Indirect Tensile Dynamic Modulus, Incremental Repeated Load Permanent Deformation, Semi-circular bend, and Overlay Testing of Asphalt Mixtures.

The Pavetest AMPT is underpinned by Pavetest's leading edge CDAS2 digital controller, TestLab software and a full complement of accessories, hardware and software in perfect unison.

**MAIN FEATURES**

- Thermoelectric (TE) Heating/Cooling  
More reliable and environmentally friendly than mechanical refrigeration & heating elements.
- Magnetically mounted on-specimen transducer system, based on loose core LVDTs or optional epsilon extensometers.
- Gauge point fixing jig facilitates gluing gauge points and the (top and bottom) platens for proposed AMPT Direct Tension Cyclic Fatigue (S-VECD) Test.
- Dynamic Verification Device.
- Dynaflo™ HPS provides dynamic speed control of the pump motor ensuring quiet operation.
- Optional built-in, silent, air compressor with associated air preparation equipment.

The machine includes:

- 8 Channel Control and Data Acquisition System (CDAS2) & TestLab software
- 30 mm Actuator LVDT
- Load cell ( $\pm 20$  kN)
- Pressure transducer ( $\pm 300$  kPa)
- Temperature transducer ( $-80$  °C to  $+ 80$  °C)
- Magnetically mounted on-specimen LVDT (2 mm) (3 pieces)
- 105 mm bottom loading platen
- 105 mm top loading platen

It requires pressurized air, minimum 4 bar (not included).



**B200L AMPT/SPT Asphalt Mixture Performance Tester**

## TECHNICAL SPECIFICATIONS

<b>Load capacity:</b>	19kN (Static) - 17kN (Dynamic)
<b>Actuator stroke:</b>	30 mm
<b>Specimen size:</b>	100 mm (diameter) x 150 mm (h)
<b>Temperature range:</b>	-10 °C to 70 °C *(B200L)
<b>Confining pressure:</b>	0 to 225 kPa
<b>Noise level:</b>	Less than 70 db at 2 m
<b>Power Supply:</b>	230V 50-60Hz 1ph 3.5kW
<b>Dimensions:</b>	1510(h) x 680(d) x 1200(w) mm 1870(h) x 680(d) x 1200(w) mm with raised cell
<b>Weight:</b>	330 kg approx. (including oil)

\* At an ambient temperature of +23 °C

## NEEDED ACCESSORIES

**B201 KIT** AMPT Consumables kit. Comprises:

- **B253-53** Gauge point (24 pieces)
- **B201-52** 5 Minute, two part epoxy 24 ml
- **S311-03** 100 mm Sealing Rings (Pack of 10)
- **B201-53** 100 mm Rubber membrane 0.3 mm thickness (Pack of 10)
- **B200-10** Latex membrane material cut in 100mm diameter discs (needed for AASHTO T378) (2 **needed** pieces)
- **B200-04** 100 mm AMPT tension platens (2 **needed** pieces) for S-VECD test



**B200-04** 100 mm AMPT tension platens

## OPTIONAL ACCESSORIES

- B270-18** Membrane stretcher for asphalt specimen Ø 100 mm (optional)
- B200-09** Spacer to enable 130mm tall specimens to be tested in tension/compression (S-VECD test on small specimens)
- B204-14** AMPT silent air compressor
- B204-11X** AMPT silent air compressor 230V 60Hz



Asphalt specimen  
with on-specimen LVDTs and load cell

## RECOMMENDED ACCESSORIES

- B202** Gauge Point Fixing Jig
- B202-04** Spacer for 130 mm specimen height to be used with gauge point fixing jig B202
- B203** AMPT Dynamic Verification Device
- H009-01EN** PC complete with LCD monitor 22", keyboard, mouse, cables and installation of Testlab software



**B202** Gauge point fixing jig



**B203** AMPT Dynamic Verification Device

**TESTING KITS**

**B204 KIT** Overlay kit according to ASTM WK26816. Comprises:

- **B204-01** Overlay jig
- **B204-02** Pair of Overlay Tester (OT) specimen plates
- **B204-03** OT specimen preparation jig according to ASTM WK26816

**B204-01 KIT** Overlay kit according to TEX-248-F. Comprises:

- **B204-01** Overlay jig
- **B204-02** Pair of overlay tester (OT) specimen plates
- **B204-13** OT specimen preparation jig according to TEX-248-F

**B207-01 KIT** AMPT Indirect Tensile (IDT) kit. Comprises:

- **B207-01** AMPT IDT Jig
- **B253-01** LVDT mounting Jig
- **B253-03** Gauge point template (150 mm specimen)
- **B290-04N** AMPT Miniature LVDT (1 mm) (4 pieces)
- **B253-53** Gauge point (32 pieces)
- **B207-02** Cable gland (4 pieces)

**B254-02 KIT** AASHTO T393 | ASTM D8044 SCB testing kit. Comprises:

- **B208** SCB frame
- **B254-10** Roller support
- **B254-02** Springs and roller
- **B254-03** Upgrade for AASHTO TP124 Method A

**B253-01 KIT** Combined IDT/SCB testing kit. Comprises:

- B253** Indirect tensile modulus, creep compliance and strength using on-specimen transducers
- B253-01** LVDT mounting jig
- B253-03** Gauge point template (150 mm specimen)
- B290-04N** AMPT miniature LVDT (1 MM) (4 pieces)
- B253-53** Gauge point (32 pieces)
- B207-02** Cable gland (4 pieces)
- B254-10** Roller support
- B254-02** Springs and roller
- B254-03** Upgrade for AASHTO T393 Method A (2 pieces)



**B204 KIT** Overlay kit according to TEX-248-F & ASTM WK26816



**B254-02 KIT** AASHTO T393 | ASTM D8044 SCB testing kit



**B207-01 KIT** AMPT indirect tensile kit

**CDAS2 - Control and Data Acquisition System**

Pavetest's compact Control and Data Acquisition System (CDAS2) delivers unparalleled performance, real time control and ultimate versatility in acquisition. The AMPT has a stand-alone CDAS2, which is common to all Pavetest systems.



CDAS2

**SMALL SPECIMENS ACCESSORIES | AMPT**

For dynamic modulus on 38 mm (diameter) x 110 mm (h) specimen:

- B200-05** Bottom loading platen for 38 x 110 mm ( $\emptyset$  x h) specimen
- B200-06** Top loading platen for 38 x 110 mm ( $\emptyset$  x h) specimen
- B202** Gauge Point Fixing Jig
- B202-02** Spacer for 110 mm specimen height to be used with gauge point fixing jig B202
- B202-03** 38 mm and 50 mm diameter specimen - extension for gauge point fixing jig plungers B202
- B253-53** Gauge point (32 pieces)
- B201-52** 5 Minute, two part epoxy 24 ml
- S311** Sealing ring  $\emptyset$  38 mm (10 pcs)
- S310** Rubber membrane  $\emptyset$  38 mm (10 pcs)
- B270-20** Membrane stretcher for asphalt specimen  $\emptyset$  38 mm

For S-VECD test on 38 mm (diameter) x 110 mm (h) specimen:

- B200-11** 38MM AMPT tension platen (2 pieces needed)
- B202** Gauge Point Fixing Jig
- B202-02** Spacer for 110 mm specimen height to be used with gauge point fixing jig B202
- B202-03** 38 mm and 50 mm diameter specimen - extension for gauge point fixing jig plungers B202



**B202** Gauge Point Fixing Jig + accessories for small specimens preparation

**RECOMMENDED ACCESSORIES FOR AASHTO TP 133 and AASHTO T378**

**B207 KIT** Quad gauge point and tension gluing jig and hardware kit, comprises:

- B202-07** Quad gauge point and tension gluing jig
- B202-08** Segment clamp (8 pieces)
- B202-09** Gauge point (72 pieces)
- B200-14** 38 mm diameter plate for 110 mm height specimen (8 pieces)
- B200-15** 100 mm diameter plate for 130 mm height specimen (8 pieces)
- B200-16** Load cell tension base for cyclic fatigue
- B200-17** Top loading plate for cyclic fatigue
- B200-18** Male thread adaptor for cyclic fa

For dynamic modulus on 50 mm (diameter) x 135 mm (h) specimen:

- B200-07** Bottom loading platen for 50 x 135 mm ( $\emptyset$  x h) specimen
- B200-08** Top loading platen for 50 x 135 mm ( $\emptyset$  x h) specimen
- B202** Gauge Point Fixing Jig
- B202-01** Spacer for 135 mm specimen height to be used with gauge point fixing jig B202
- B202-03** 38 mm and 50 mm diameter specimen - extension for gauge point fixing jig plungers B202
- B253-53** Gauge point (32 pieces)
- B201-52** 5 Minute, two part epoxy 24 ml
- S311-01** Sealing ring  $\emptyset$  50 mm (10 pcs)
- S310-01** Rubber membrane  $\emptyset$  50 mm (10 pcs)
- B270-21** Membrane stretcher for asphalt specimen  $\emptyset$  50 mm

For S-VECD test on 50 mm (diameter) x 135 mm (h) specimen:

- B200-12** 50MM AMPT tension platen (2 pieces needed)
- B202** Gauge Point Fixing Jig
- B202-01** Spacer for 135 mm specimen height to be used with gauge point fixing jig B202
- B202-03** 38 mm and 50 mm diameter specimen - extension for gauge point fixing jig plungers B202



**B202-07** Gluing jig

## B215 SERVO-PNEUMATIC OVERLAY TESTER

The Pavetest Overlay Tester is a servo-pneumatic controlled testing machine utilizing digital control of a high performance servo valve to provide accurate loading wave shapes up to 60Hz, specifically designed to determine the susceptibility of asphalt mixtures to cracking according to Texas DOT test procedure Tex-248-F and proposed ASTM Standard WK 26816.

The machine applies cyclic loading to a specimen that is cut from a 150 mm diameter sample into the shape of a rounded end beam. The system comprises a load frame, with one fixed and one moving plate, temperature control system, Control and Data Acquisition System (CDAS2) and optional silent air compressor. The specimen is glued to two plates and this assembly is placed in the machine for testing. This is intended to simulate the action of movement under an asphalt overlay to assess how failure might occur in the field due to factors such as thermal expansion / contraction and reflective cracking.

The Pavetest Overlay Tester is underpinned by Pavetest's leading edge CDAS2 digital controller, TestLab software and all the necessary accessories, hardware and software in perfect unison.

### MAIN FEATURES

- Compact, fully self contained, precision engineered unit.
- Thermoelectric (TE) Heating/Cooling - More reliable and environmentally friendly than mechanical refrigeration & heating elements.
- Optional silent, air compressor including membrane dryer.
- Built in verification (Dial gauge).
- Integral stand with wheels.

The machine includes:

- Load frame with one fixed and one moving plate
- 15 kN Servo-pneumatic actuator (10 mm stroke)
- 8 Channel Control and Data Acquisition System (CDAS2) & TestLab software
- Load cell ( $\pm 15\text{kN}$ )
- 10 mm displacement transducer
- Thermoelectric Heating/Cooling system
- Temperature transducer  $-80\text{ }^{\circ}\text{C}$  to  $+80\text{ }^{\circ}\text{C}$

It requires pressurized air, minimum 7 bar (not included)



**B215** Overlay tester

## TECHNICAL SPECIFICATIONS

<b>Load Capacity:</b>	Up to 16 kN (Static)
<b>Actuator stroke:</b>	10 mm
<b>Temperature range:</b>	10 to 60 °C
<b>Noise Level:</b>	Less than 70 db at 2 m
<b>Power supply:</b>	110/230V 50-60Hz 1ph 750W (B215)
<b>Dimensions:</b>	980 (h) x 475 (d) x 1085 (w) mm
<b>Weight:</b>	150 kg approx.

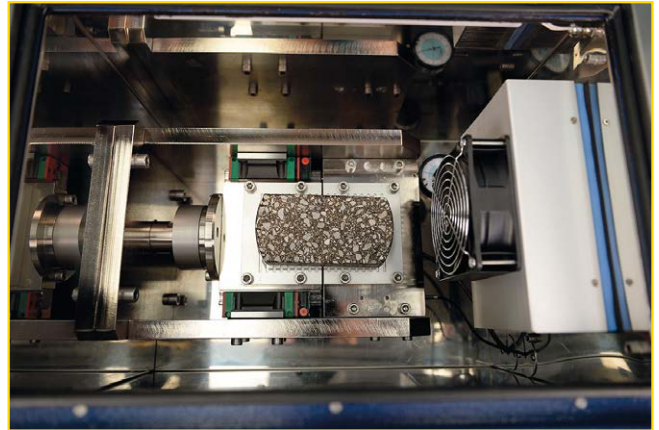

**B215** Overlay tester: detail

## TECHNICAL FEATURES

- **Temperature controller.** The overlay tester is fitted with a temperature controller, which controls the heating/cooling provided by the thermo-electric unit fitted to the machine.
- **The specimen preparation jig allows users to properly locate and glue the specimen on plates.** It can accommodate up to three sets of platens. It includes 2 mm teflon strip, which helps aligning the specimen plates and eliminate the need to saw the glue afterwards, and a dead weight.
- **The Overlay Tester main unit comes fully assembled.** It can be placed on the folding stand supplied, complete with wheels.

## NEEDED ACCESSORIES

**B204-02** Pair of specimen plates

**B204-03** OT specimen preparation jig according to ASTM WK 26816

**B204-13** OT specimen preparation jig according to Tex-248-F

**Note:** The quantity depends on the customer's need.

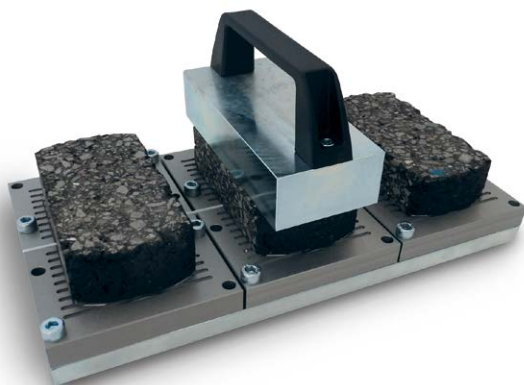

**B204-03** Specimen preparation jig



Detail of the wheels



**B204-02** Specimen plates

## OPTIONAL ACCESSORIES

**B204-11** Silent air compression 750W 230V 50Hz

**B204-11X** Silent air compression 750W 230V 60Hz

## TSRST-MULTI

### MULTI STATION THERMAL ASPHALT SYSTEM

#### STANDARDS:

**AASHTO TP10-1993** Standard test method for Thermal Stress Restrained Specimen Tensile strength

**EN 12697-46:2012** Test methods for hot mix asphalt Part 46: Low temperature cracking and properties by uniaxial tension tests

## FIRST STAND ALONE SERVO-HYDRAULIC TSRST



TSRST-MULTI STATION

#### MAIN FEATURES

- Up to three working stations (electromechanical and/or servo-hydraulic stations).
- Servo-hydraulic actuator: 30 kN static, 25 kN dynamic, double acting, fatigue rated and equal area type with long life Labyrinth bearings & seals.
- Dynaflo™ Hydraulic Power Supply: Variable Frequency Drive 2.2 kW pump motor; Silent operation.
- Ability to clone, modify and/or generate user's own method file(s) to suit their specific requirements.
- Programmable test Wizard to guide the operator step by step based on a recipe book approach.
- Temperature controller programmed via PC software.

#### The machine includes:

- 16 Channel Control and Data acquisition System (CDAS-2) & TestLab software
- Climatic chamber -40°C to +40°C, cooling rate of 10°C per hour. Optional version -50°C to +40°C (AASHTO TP 10)
- Loading frame(s) with two rigid columns, work space of 240 mm wide and 285 mm high
- Electro-mechanical or Servo-hydraulic actuator(s) based on the chosen configuration
- Load cell(s)  $\pm 30\text{kN}$ , 0,1%
- Refrigeration Unit

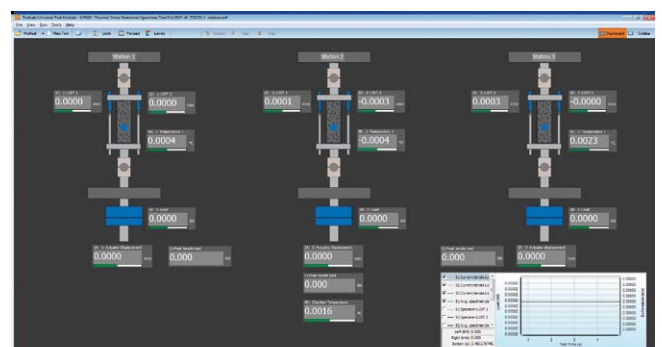

TSRST-Multi Dashboard showing the test status for each axes

## TECHNICAL SPECIFICATIONS

### External dimensions load frame (including environmental chamber):

1853(h) x 1020(d) x 1230(w) mm

### Hydraulic Power Supply (for Servo-hydraulic station(s):

700(h) x 520(d) x 570(w) mm

**Weight load frame:** 200 kg approx. without the selected stations configuration

### Electrical requirement for:

**Servo-hydraulic station (each):** 230V 50-60Hz 1ph 2.2kW

### Electro-mechanical station (each):

100-230V 50-60Hz 1ph 0.75kW

**Refrigeration unit:** 380-420V 50Hz 3ph 2.5kW

### Electro-mechanical actuator(s)

- 25kN static with  $\pm 50$  mm stroke (100 mm)
- Internal displacement transducer

### Servo-hydraulic actuator

- 30kN static, 25kN dynamic, double acting, fatigue rated, servo hydraulic actuator, equal area type with long life seals & bearings
- $\pm 50$  mm stroke (100 mm)
- Internal displacement transducer
- Close coupling of servo valve to actuator for best servo performance
- 10  $\mu$ m pressure line filter at actuator for ultimate contamination control
- 0.5 lt hydraulic accumulator with 40 Bar pre-charge for best pressure line regulation at servo-valve.
- High response, VCD direct drive, servo-valve: -3 db @ 350 Hz,  $\pm 5\%$  amplitude (performance curves available on request)

### Load cell(s)

- Low profile Precision Transducers load cell,  $\pm 30$ kN, 0.1%. Normalized output with in-line signal conditioning

### Hydraulic power supply

- Working pressure of up to 160 Bar (low pressure adjustable)
- High/Low pressure selectable from control pendant
- Variable flow rate up to 7.5 liter/min
- Variable Frequency Drive (VFD) 2.2kW pump motor; speed based on demand
- 3  $\mu$ m return line filtration
- Low oil, over temperature and dirty filter displayed
- Remote starting
- Pressure gauge
- Air cooling (Electric fan)



**B282-08** TSRST specimen gluing jig (needed accessory)

Simple and easy to use gluing jig for preparing TSRST specimens. The jig provides for perfect alignment and adjustment for different sized specimens. The clamping force is easily set and ensures the end plates are glued perpendicular to the specimen.

## ORDERING INFORMATION

All available configurations are summarized in the following table:

	ELECTROMECHANICAL STATION	SERVO-HYDRAULIC STATION
<b>B282-10</b>	1	-
<b>B282-11</b>	2	-
<b>B282-12</b>	3	-
<b>B282-13</b>	-	1
<b>B282-14</b>	1	1
<b>B282-15</b>	2	1

### Note:

Multiple stations configuration (B282-11, B282-12, B282-14, B282-15) allow to run tsrst tests with all stations simultaneously. In this configurations, UTST, RT, TCT, UTSST and UTCST tests are performed on one station at a time. With combined configuration (electromechanical and servo-hydraulic) UTCST must be performed with servo-hydraulic station.

## TO PERFORM

- Uniaxial tension stress test (UTST)
- Thermal stress restrained specimen test (TSRST)
- Relaxation time, using the relaxation test (RT)
- Tensile creep tests (TCT)
- Uniaxial cyclic tension stress tests (UCTST)\*\*
- Uniaxial thermal stress & strain test (UTSST)\*\*\*

\*\* Only applicable to servo-hydraulic work station(s)

\*\*\* Additional hardware required

## ACCESSORIES

**B282-08** TSRST specimen gluing jig (needed)

**B282-18** TSRST proof test assembly (optional)

Disk Shaped Compact Tension test:

**B284-01** Disk-shaped compact tension test jig

**B282-02** Rod ends (2 pieces needed)

**B290-07N** SCB deformation gauge (needed)

or

**B290-12N** Epsilon (model 3541) clip-on gauge CMOD transducer +1/-7 mm (Alternative to B290-07N)

**C090-18** Knife edge (pack of 24) only for B290-12N

## S205M

### UNITRONIC 50 kN UNIVERSAL MULTIPURPOSE TOUCH-SCREEN FRAME FOR COMPRESSION / FLEXURAL AND TENSILE TESTS WITH AUTOMATIC LOAD OR DISPLACEMENT/DEFORMATION CONTROL

By using suitable devices, Unitronic tester, within the limits of its max. 50 kN capacity for compression/flexural and 25 kN for tensile (see accessory S205-05M), performs compression, flexural, indirect tensile and direct tensile tests, with automatic load or displacement/deformation control.

The load is applied by a mechanical jack that is driven by a motor **brushless with closed loop through optic encoder** and controlled by a microprocessor. Stroke electric end switches are applied to the load piston to save the machine from accidental handlings.

The two crossheads foresee couplings to fix the different test devices (see accessories). The stress is measured by an electric load cell; the measurement and the displacement control of the crosshead is achieved by the electronic device incorporated into the machine.

#### TECHNICAL SPECIFICATIONS

- Maximum compression capacity: 50kN
- Maximum tensile capacity: 25kN (accessory S205-05M)
- Adjustable testing speed from 0.01 to 51 mm/minute
- Adjustable pace rate from 1 to 15000N/sec.
- Max. ram travel: 100 mm
- Daylight between columns: 380 mm
- Max. vertical daylight: 850 mm
- Unitronic 50 kN is supplied without accessories and software to perform the specific tests that must be ordered separately.

**Power supply:** 230V 1F 50-60Hz 1500W

**Dimensions:** 500x450x1450 mm

**Weight:** 130 kg approx

#### SPECIFIC APPLICATIONS ON BITUMINOUS MATERIALS

##### B256 KIT

##### Ideal RT

STANDARD: ASTM D8360-22

Standard Method for Determination of Rutting Tolerance Index of Asphalt Mixture Using the Ideal Rutting Test

Ideal RT comprises:

**B256-01** Ideal RT Jig

**B250-01** Basic IDT Jig

##### B257 KIT

##### Ideal CT

STANDARD: ASTM 8225

Indirect Tensile Asphalt Cracking Test

Ideal CT comprises:

**B253** Indirect tensile modulus, creep compliance and strength using on-specimen transducers

**B253-06** Loading Strips



**S205M** with load cell

#### INDIRECT tensile test

STANDARDS:

EN 12697-23 | ASTM D6931

AASHTO T283 | CNR 134

Test development with displacement control.



#### NEEDED ACCESSORIES

**S337-34** Strain gauge load, 50 kN capacity

**4xS337-51** Calibration process of load cell/transducer

**S212-05** Loading piston

**B047-02** Indirect tensile device for samples Ø 4" and 6"

**B047-04** Set of TWO displacement transducers with accessories

**B043-02N** Software for Indirect Tensile test

**S336-14** Linear displacement transducer 50 mm stroke, complete with cables and connectors

**S305-05** Mounting device of the coupling pliers

**S335-15** Coupling pliers to hold transducers

## S205M SCB-SEMI CIRCULAR BEND TEST

THE FAST AND SIMPLE WAY TO PERFORM ASPHALT FRACTURE TESTING

STANDARDS: EN 12697-44 | AASHTO TP124 | ASTM D8044

The S205M universal frame can perform various versions of the SCB Test for evaluating the fracture characteristics of asphalt mixtures at intermediate service temperature conditions. The load and displacement parameters measured by the Automatic SCB system can be used to predict cracking performance of asphalt mixtures based on the Illinois Flexibility Index (I-FIT) and Critical Strain Energy Release Rate (Jc).



S205M + SCB accessories



Asphalt specimen positioning



Detail of the configuration

### Standard EN 12697-44

Tensile strength and fracture toughness-crack propagation.

#### NEEDED ACCESSORIES

- B250-01** Basic indirect tensile (idt) jig, for 100-150 mm diameter
- B254-01** Scb jig (requires basic idt jig)
- B254-51** Pair of scb wear plates
- S337-34** Load cell 50 kn capacity
- B045-13** Loading piston
- S336-15** Transducer type "B" travel: 10 mm
- B045-14** Coupling hardware
- S335-15** Universal coupling pliers for transd./dial
- B043-05N** Software for auto-scb test

### Standards AASHTO TP124

Determining the fracture potential of asphalt mixtures using semicircular bend geometry (scb) at intermediate temperature.

### ASTM D8044

Evaluation of asphalt mixture cracking resistance using the semi-circular bend test (SCB) at intermediate temperature.

#### NEEDED ACCESSORIES

- B208** SCB frame
- B254-02** Springs
- B254-10** Roller support
- S337-31(\*)** Load cell 2,5 kn capacity
- B045-13** Loading piston
- S336-15** Transducer type "B" travel: 10 mm
- B045-14** Coupling hardware
- S335-15** Universal coupling pliers for transd./dial
- B043-05N** Software for auto-scb test

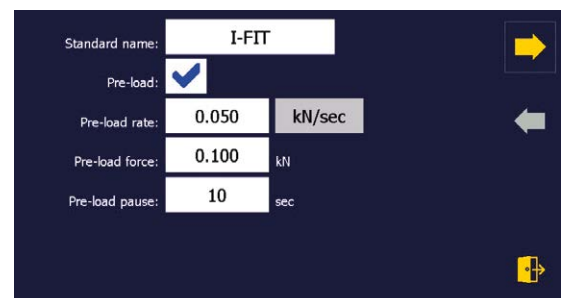

Firmware interface

#### OPTIONAL ACCESSORIES

- B254-12** Positioning device

(\*) As alternative to item S337-31

- S337-32** Load cell 10 kN capacity
- S337-33** Load cell 25 kN capacity
- S337-34** Load cell 50 kN capacity
- S337-35** Load cell 5 kN capacity

## BITUMEN SUPERPAVE EQUIPMENT

Bitumen, as with all civil construction materials, is characterized by its mechanical properties. The first classification used in the past, and actually still working in many Countries nowadays, is based on **empirical properties**, such as penetration, softening point, breaking point and ductility. The importance of a performance analysis has been developed only in the last 20 years: by adopting empirical test procedures, bitumen mechanistic behaviour is not investigated, the test procedures are influenced by the operators and innovative binders cannot be properly tested.

Also, the traditional classification (such as penetration or viscosity grade) provides ambiguous results.

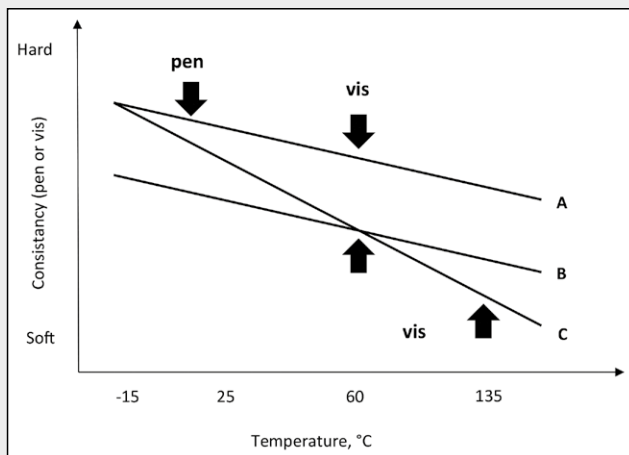

Example of empirical test comparison

In fact, two bituminous binders may have the same properties at different test temperature and much different behaviour at other ones.

The need to understand the mechanical properties and relation between the material and the damage that occurs during the service life of road pavement (low temperature cracking, fatigue cracks and rutting deformations) was the motivation behind the development of a new classification system known as **Superpave**: Superpave is an acronym for **Superior Performing Asphalt Pavements** and it is a new, comprehensive asphalt mix design and analysis system, developed by Strategic Highway Research Program (SHRP) to improve the performance and durability of roads. This method is different from the previous one and it is based on **PERFORMANCE**: focusing on bituminous binder, the modern classification introduced by Superpave is based on **Performance Grade (PG)**.

A unique feature of the Superpave system is that the tests are performed at temperatures and aging conditions that more realistically represent those encountered by in-service pavements. The Superpave PG binder specification requires the testing of the asphalt binder under project's expected climatic and aging conditions in order to help in reducing pavement distress. SHRP researchers developed new equipment standards as well as incorporated equipment used by other industries to develop the binder tests.

SUPERPAVE EQUIPMENT	PURPOSE
Dynamic Shear Rheometer (DSR)	Measure properties at high and intermediate temperatures
Rotational Viscosimeter (RV)	Measure properties at high temperatures
Bending Beam Rheometer (BBR) and Direct Tension Tester (DTT)	Measure properties at low temperatures
Rolling Thin Film Oven (RTFO)	Simulate hardening during asphalt production phase
Pressure Aging Vessel (PAV)	Simulate hardening during pavement life

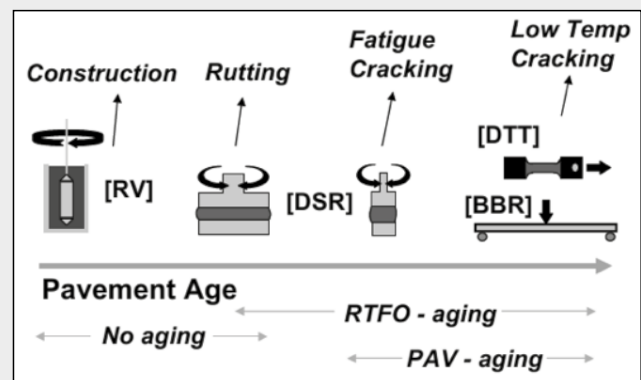

PG Testing Procedure

The new performance-based classification system introduces the **binder rheology based innovative testing conditions that real replicate the binder behaviour** from the construction phase including the concept of properties evolution due to ageing. Employing the new Superpave approach measures physical properties that can be related directly to field performance utilizing engineering principles. The key detail is that the Superpave tests characterize asphalt at a wide range of temperatures and aging. Superpave characterizes them at the actual pavement temperatures that they will experience, and at the periods of time when the asphalt distresses are most likely to occur.

## B225-09 DTT DIRECT TENSION TESTER

STANDARDS: AAHSTO T 314-12 Determining the Fracture Properties of Asphalt Binder in Direct Tension

The Pavetest DTT Direct Tension Tester is an electro-mechanical servo-controlled testing machine utilizing digital control of a high performance electro-mechanical actuator to provide accurate loading rates up to 50 mm/minute, designed to determine the fracture properties of Asphalt binder in Direct Tension (DTT). The machine is fitted with a temperature controlled cabinet (-40 °C to +80 °C) and a direct tension jig, complete with 25 mm on specimen displacement transducer. The unit is underpinned by Pavetest's leading edge CDAS2 digital controller, TestLab software and a full complement of accessories hardware and software in perfect unison.



B225-09 DTT Direct Tension Tester



Horizontal configuration



B225-10

### NEEDED ACCESSORIES

- B225-12** DTT specimen tab (2 pcs)
- B225-13** DTT specimen mould assembly
- B225-10** Direct Tension jig complete with 25 mm on specimen displacement transducer



Temperature controlled unit- REFR. UNIT

### OPTIONAL ACCESSORY

- H009-01EN** PC 22" with lcd screen

## B091M

### PAV

## PRESSURE AGEING VESSEL

STANDARDS: EN 14769 | ASTM D6521 | AASHTO R28

PAV to simulates in-service oxidative aging that occurs in asphalt binders during service after 5 to 10 years (long-term aging). The sample is exposed to high pressure and temperature for 20 hours (selectable up to 99). The Pressure Ageing Vessel (PAV) features 100% compliance with the laboratory standards related to aging the bitumen. The unit consists of a stainless steel vertical pressure vessel (AISI 304 with ASME and CE certifications) enclosed in a cabinet with encased band heaters. A source of compressed air with a pressure of at least 2.1 MPa and a pressure regulator generates and maintains the aging condition required.

### MAIN FEATURES

- Sturdy stainless steel frame and vessel.
- Fast pre-heating system selectable up to 60 °C in order to reduce the conditioning time.
- Timer for setting time and date to start the machine at the desired time.
- Innovative cooling system.
- Fully automatic, Semi-Automatic and Manual tests.
- Temperature and pressure monitored in real time.
- Integrated 7" colour Touch screen controller.
- Pressure monitored in real time by transducer and controlled to  $2.1 \pm 0.1$  MPa.
- CE and ASME certification.

The unit is equipped with a 7" colour Touch screen controller with front panel user interface with easy to use step-thru operation. The user-friendly software allows the operator to carry out the test in different modes:

- **AUTOMATIC:** It's possible to select from 4 different temperatures (85, 90, 100, 110 °C) and 2 different testing time (20 or 65 hours).
- **SEMI-AUTOMATIC:** It's possible to select a temperature from 60 to 120 °C and run the test for 20 or 65 hours as in the automatic mode;
- **MANUAL:** This mode can be used in research and it allows to manually select the temperature from ambient to 130 °C and the testing time from 1 to 99 hours.

**Temperature and pressure can be monitored in real time**, thanks to a platinum RTD probe and a pressure transducer. Data logs of both temperature, aging time and pressure are saved on USB stick at the end of the test.

A pre-heat mode allows to reach a maximum of 80 °C before introducing the sample in safety conditions reducing the conditioning time of the sample that can reach faster the test temperature. Thanks to an innovative heating system and the pre-heating mode the test can start in around 1 hour.

The instrument is supplied complete with a sample rack for the simultaneous testing of ten specimens, ten specimen pans as per standards, but without compressed air source, 2.1Mpa minimum pressure.



**B091M**

### TECHNICAL SPECIFICATION

- Operating pressure:  $2.1 \pm 0.03$  Mpa (304 psi)
- Programmable temperature range: from ambient temperature to 130 °C, res:  $\pm 0.1$  °C
- Programmable pre-heating function: up to 60 °C
- Test temperature uniformity:  $\pm 0.5$  °C
- Testing time: up to 99 hours
- Safety equipment in all test conditions: Over pressure relief valve and Over temperature limit switch.

**Power supply:** 230V 1Ph 50Hz 10A

**Dimensions:** 450x650x500 mm approx.

**Weight:** 80 Kg approx.

### ACCESSORY

**B091M-11** PRESSURE REGULATOR to connect the compressed air tank to the PAV, for an adequate inlet pressure.

**B091M-12** AIR FILTER

### SPARES

**B091M-10** Sample rack, for testing up to 10 samples at the same time

**B064-04** Stainless steel container, diameter 140x9.5 mm



**B091M-10**

### B091M1

### PAV - RESEARCH VERSION

Same to B091M but implemented with an electronic pressure valve to adjust the test pressure from ambient to 2.4 MPa, regulated from the control panel.

**B091M-01****VDO****VACUUM DEGASSING OVEN**

STANDARDS: EN 14769 | ASTM D6521 | AASHTO R28

The long-term aging of bitumen and bituminous binders obtained by a Pressure Ageing Vessel (PAV), generates air bubbles which must be removed in accordance with EN 14769, ASTM D6521 and AASHTO R28 standards. The Vacuum Degassing Oven, (VDO) consists of a stainless steel vacuum vessel with a hinged lid to conserve space and access the vacuum chamber. It can hold up to 8 specimen containers. The unit allows selectable working temperature range from ambient to 200 °C with a resolution of  $\pm 0.1$  °C, measured by a platinum RTD probe. The VDO guarantees the required operating pressure of  $15 \pm 1$  kpa for the achievement of vacuum.

**MAIN FEATURES**

- Sturdy stainless steel frame.
- Temperature is measured by Platinum RTD.
- Pressure release valve.
- Over temperature limit switch.
- Fully automatic, Semi-Automatic and Manual test;
- Temperature and pressure monitored in real time.
- Automatic release of the pressure at the end of the test.
- Fast heating and vacuum system to reach set point.
- USB port on front unit with software upgrades and data storage.
- 7" colour touch screen controller with front panel user interface for temperature, vacuum, set points and actual values.

The unit is equipped with a 7" colour Touch screen controller indicating: temperature and pressure in real time and current stage of each process. The user-friendly software allows the operator to carry out the test in different modes:

- **AUTOMATIC:** Maintains the temperature constant at 170 °C for 30 minutes as required by the standards
- **SEMI-AUTOMATIC:** Selectable test temperature from ambient to 200 °C and the test runs for 30 minutes as in automatic mode
- **MANUAL:** Selectable both test temperature from ambient to 200 °C and time up to 99 minutes for research purposes

At the end of the test it is possible to obtain uniform bitumen samples that can be used for further analysis to identify Performance Grade (such as DSR, DTT and BBR) or conventional bitumen properties (such as penetration, ductility, softening point among others)

**B091M-01****TECHNICAL SPECIFICATION**

- Operating pressure:  $15 \pm 1$  Kpa, res:  $\pm 0.1$  Kpa
- Test temperature:  $170 \pm 4$  °C, res:  $\pm 0.1$  °C
- Working temperature range: Ambient °C to 200 °C
- Power supply: 230V 1ph 50Hz
- Dimensions: 430x450x470 mm approx
- Weight: 30 kg approx.

**SPARE**

**B091M-20** Sample holder for 4  $\varnothing$  70x45 mm sample cup and for 8/10  $\varnothing$  55x35 mm sample cup

**NEEDED ACCESSORIES**

- V122-05** Sample cup, brass made,  $\varnothing$  55x35 mm
- V122-06** Sample cup, brass made,  $\varnothing$  70x45 mm

**B091M-20**Backside of **B091M-20**

B216

BBR PLUS

**SERVO-CONTROLLED BENDING BEAM RHEOMETER**

The BBR is a thermoelectrically-cooled bending beam rheometer for testing flexural creep of asphalt binders from ambient to  $-40\text{ }^{\circ}\text{C}$  ( $\pm 0.03\text{ }^{\circ}\text{C}$ ). The load is applied by a miniature servo-controlled actuator capable of applying up to  $\pm 10\text{N}$  and loading frequency from static to 25Hz, without the need for compressed air supply. The use of servo-control eliminates the need for frequent calibration and repeated adjustment of air bearing pressures. Just enter the required load and the servo-controlled actuator will apply and maintain the requested load with incredible precision. The temperature is controlled very precisely using a temperature controller mounted on the front of the machine\*. **The user can set the bath temperature using the controller or via the software. The heart of the system is Pavetest's industry leading Control and Data Acquisition System (CDAS 2) and world acclaimed (TestLab) software.**

\*The BBR is supplied with a suitable chiller to ensure temperature range between ambient and  $-40^{\circ}\text{C}$ .

**MAIN FEATURES**

- Servo-control eliminates the need for frequent calibration and repeated adjustment of air bearing pressures
- Loading frequency from static to 25Hz
- No need for compressed air supply
- TE-cooled with solid-state Peltier devices
- Includes a separate air-water heat exchanger
- An integrated, self-contained bath cools using ethanol as the bath medium
- Set and monitor the temperature of the bath via the software

**TECHNICAL SPECIFICATIONS**

- Meets or exceeds ASTM, AASHTO and SHRP requirement for low temperature flexural creep testing of asphalt binders including ASTM D6648 and AASHTO T313
- Temperature range: Ambient to  $-40\text{ }^{\circ}\text{C}$
- Temperature stability:  $\pm 0.03\text{ }^{\circ}\text{C}$
- Resolves specimen beam deflection to  $0.01\text{ }\mu\text{m}$
- Load cell span: 50 N
- Load cell resolution:  $50\text{ }\mu\text{N}$
- Range: 20 MPa to 1 GPa
- Loading frequency from static to 25Hz

**Power supply:**

BBR: 100-230V 50-60Hz 1ph 850W  
 Chiller: 230V 50-60Hz 1ph 590W  
 110V 50-60Hz 1ph

**Dimensions:** BBR: 60 x 50 x 52(h) cm  
 Chiller: 47 x 53 x 40(h) cm

**Weight:** BBR: 39 kg  
 Chiller: 48 kg

## Common Applications

- Flexural creep of asphalt binders
- Low temperature characterization of crack seal under load
- ASTM D6648, AASHTO T313, EN 14771, SHRP Binder Provisions For Low Temperature Flexural Creep Testing of Asphalt Binders

## CDAS2 - CONTROL AND DATA ACQUISITION SYSTEM

The BBR integrates Pavetest's compact Control and Data Acquisition System, complete with the TestLab Software, delivers unparalleled performance, real time control and ultimate versatility in acquisition and provide a flexible and user-friendly testing solution.

### MAIN FEATURES

- Compact up to 8 Input, 2 control axis.
- Sampling rate up to 200 kHz over all channels.
- Up to 64 times over-sampling.
- Up to 24 bit resolution over the full range (no auto ranging required).
- Automatic recognition of transducers and upload of calibration files.
- Digital closed loop update sampling rate up to 30 kHz over all axes.
- High speed, (18 bit) D/A digital servo-control.
- Modbus/CAN/RS485/RS232 communication among devices connected to the same network.
- Communication USB or Ethernet.
- Optional wireless colour touch screen display/controller.

## TESTLAB, A NEW APPROACH - TOTALLY OPEN AND PROGRAMMABLE SOFTWARE

With TestLab software, any kind of test can be designed, cloned and/or modified by the user. The user is no longer limited to the test configuration established at the time of purchase; the possibilities are limited only to her/his ability and imagination.

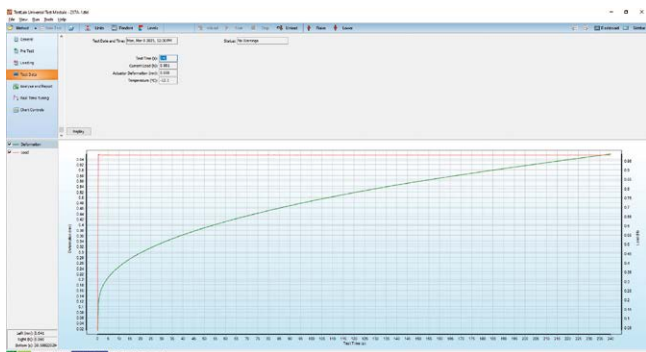

Suite equipped with pre set or customized Method File

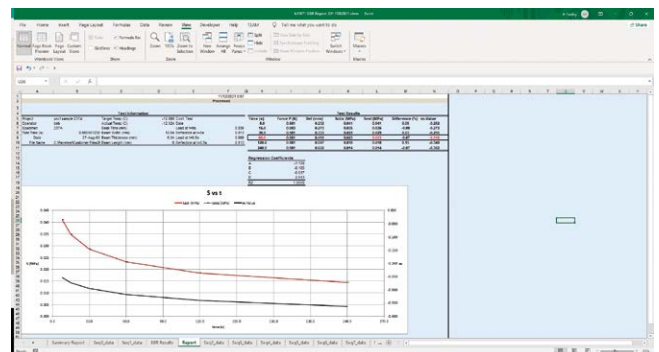

Post elaboration integrated function with Excel data.

## ORDERING INFORMATION

### NEEDED ACCESSORIES

**B216-01** Mould for BBR

**B216-06 KIT**

Comprises:

**B216-02** Temperature verification device

**B216-03** Deformation verification: gauge blocks

**B216-04** Reference beams (thick and thin)

**B216-05** Load verification kit

### SPARE PARTS

**B216-07** Strips per mould

## UPGRADE BENEFITS

Are you sick of adjusting pressure regulators on your out-dated air bearing BBR? Upgrade to a servo-controlled loading head. Our 40 plus years' experience with servo-controlled systems and instrumentation places us in strong position to restore your outdated system to current day standards.



**B003**
**AMA**
**ASPHALT MIX ANALYZER**

AUTOMATIC CLOSED-LOOP SYSTEM

STANDARDS: ASTM D8159 | EN 12697-1

The Asphalt Mix Analyzer (AMA) is an innovative device capable of combining all the processes associated with bitumen extraction and recovery.

The unit has been designed for the purpose of determining the bitumen content in asphalt mixture and it is the best solution to analyse and characterize the properties of the reclaimed asphalt pavement (RAP).

Through the use of solvent selectable from tetrachloroethene or trichloroethylene or methylene chloride\*, the final result of the process is the separation of aggregates and filler from bitumen in order to verify the quality of the recovered granular materials and determine the mineral skeleton of the mixture. On the other hand, the bitumen can be separated from the remaining solvent solution by rotary evaporation in order to make the binder available for further analysis such as DSR, DTT and BBR according to Performance Grade and conventional bitumen tests such as penetration, ductility, softening point among others.

**Note\*:** The unit is supplied without the solvent that has to be purchased independently.

**MAIN FEATURES**

- “All in one” automatic cycle with silent operation
- Combination of ultrasonic impulses and heating effect to a complete bitumen extraction
- Complete extraction in less than 1 hour (depending from the material tested), reducing costs and time
- Automatic sample drying after operation
- Complete close cycle avoiding toxic fumes for healthy environment
- Automatic passage from pre-wash to washing phase
- Possibility of using the distillation chamber only
- Forced distillation made to reduce the bitumen solution at less than 1 litre at the end of the test
- Customizable cycle: selectable pre-wash phase, number of washings, rinsing and drying cycles
- Up to 10 profiles saved
- Optional direct connection with rotary evaporation flask
- Optional integrated or external balance for automatic determination of the bitumen content
- Automatic bitumen content calculation



Mesh drum into the washing chamber



Cup into the centrifuge, up to 8000 revolutions per minute



Integrated balance for automatic weight record



Fully automatic and closed cycle

Sturdy frame and small footprint

**B003**

The unit consists in a **stainless-steel washing chamber** where the user introduces the asphalt sample up to 3.5 kg. Subsequently, thanks to an accurate centrifugation process, the filler is separated and collected into the centrifuge cup while the bitumen solution is drained off to the solvent recovery chamber. Most of the solvent is recovered by condensation and it can be used for other extractions. The remaining part of the bitumen solution can be collected in an extraction flask after distillation, available for further analysis.

In order to perform this cycle, the unit is equipped with a **multi-layer mash washing drum** available with different openings (0.063, 0.075, and 0.090) to contain the aggregates, a **centrifuge cup** to collect the recovered filler and an extraction flask to collect the remaining bitumen solution.

Before starting washing, the unit allows to add a pre-wash phase in order to improve the process of separation and extraction of bitumen.

### TECHNICAL SPECIFICATION

- Maximum sample weight: 3.5 kg
- Centrifuge rotation speed: 8000 r.p.m.
- Scale: 10 kg, 0.1 g res.
- Cup dimensions: Ø120 mm x 200 mm height
- Extraction time: Less than 1 hour depending on the mix tested (including drying time)
- Solvent per extraction reused for several tests
- Up to 300 g of filler recovered

**Power supply:** 380V 50Hz 3Ph

**Dimensions:** 1400x750x1500 mm approx.

**Weight:** 240 kg approx.



**B003-03**



**B003-07**



**B003-06**



**B008-11**

The unit presents a **7" colour touch-screen controller** with front panel user interface with easy to use step-thru operation. The user-friendly software allows the operator to set up:

- number and duration of the prewash cycles;
- number and duration of the washing cycles;
- number of rinsing cycles;
- number and duration of the drying cycles.

The door is locked during all test phases to provide a safe environment. Furthermore, the test stops automatically in case of anomalies or malfunctions, showing the type of alarm on the display in real time. The solvent mode extraction has to be selected before supplying the unit, and the machine will be calibrated accordingly.

The Asphalt Mix Analyzer is available using the following solvents:

**B003-01** Tetrachloroethene operation mode

or

**B003-02** Trichloroethylene operation mode

or

**B003-21** Methylen chloride operation mode

### NEEDED ACCESSORIES

**B003-03** Washing drum, mesh with opening 0.063 mm

or

**B003-04** Washing drum, mesh with opening 0.075 mm

or

**B003-05** Washing drum, mesh with opening 0.090 mm

**B003-06** Closing lid for washing drums

**B003-07** Centrifuge cup, Ø120 mm, up to 200 g of filler

or

**B003-22** Centrifuge cup, Ø120 mm, up to 300 g of filler

**B008-11** Lining paper for centrifuge cup. Pack of 100

### RECOMMENDED ACCESSORIES

**B003-13N** Worktop balance for an easy and automatic determination of the bitumen content, 10 kg, accuracy 0.1 g

or

**B003-20** External balance, 15 kg, 0.1 g resolution

**B003-14** Solvent stabilizator, for recycled tetrachloroethene

**B003-15** Solvent pumping device for safe solvent filling

**B003-16** Water cooling system high end

or

**B003-19** Water cooling system

**B003-17** Device for the extraction of the centrifuge cup

**B003-18** Fast connection for rotary evaporator flask, for bitumen solution sampling

## TriaxLab Automated System

STANDARDS: BS 1377:7, BS 1377:8 | ASTM D2850, D4767, D7181 | NF P94-070, P94-074 | UNI EN ISO 17892



TriaxLab Automated System S301-01N

### MAIN FEATURES

- Type of tests: total and effective stress. Stress path, K0 and permeability are available on request.
- Servo feedback controlled precision pressure (Pressurematic) generation system.
- Real time graphing and configurable real time transducers.
- Pre-programmed user-friendly “Method files” through the TestLab Software.
- Compact and versatile for improving productivity and cost effectiveness.
- No need of air source.

Matest TRIAXLAB is an outstanding system specifically designed for advanced soil testing.

This system can be used from educational to construction engineering laboratories to reduce to the absolute minimum any form of manual intervention.

Based on the unparalleled performance of CDAS2 and flexibility of TestLab Software, the new MATEST TriaxLab Automated System is the optimized system to perform automatically total and effective triaxial tests such as:

- CD Consolidated Drained test
- CU Consolidated Undrained test
- UU Unconsolidated Undrained test
- Optional Stress path
- Optional K0 tests
- Optional Permeability tests

## TRIALAB AUTOMATED SYSTEM

### ORDERING INFO:

#### HARDWARE - SOFTWARE

##### S301-01N

##### DIGITAL TRIAXIAL LOAD FRAME 50 KN

Technical Specifications:

Maximum load capacity: 50 kN

Infinitesimal testing speed:

from 0.00001 to 12 mm/min

Minimum vertical clearance: 400 mm

Maximum vertical clearance: 1100 mm

Horizontal clearance: 380 mm

Platen diameter: 167 mm

Power Supply: 230V 1ph 50/60Hz 600W

Dimension: 495x500x1800 mm approx

Weight: 80 kg

##### S303N

##### CDAS2 AND TESTLAB SOFTWARE

Technical Specifications:

Acquisition 16 Channels 20 bit resolution

Sampling rate up to 200 kHz

(all channels)

Smoothing up to 64 times over-sampling

Calibration Automatically on power up

Control Axis 4

Communication USB or Ethernet

Power supply:

90-264 V 50/60 Hz 1 ph 240 W

Dimensions: 100(h) x 310(d) x 250(w) mm

##### S305

##### TRIAxIAL CELL MAX. Ø 70X140 MM

Technical Specifications:

Max. specimen size: mm Ø 70x140

Max. cell pressure: 1700 kPa

Overall dimensions: mm Ø 280x480

Weight: 8 kg approx.

##### S306N

##### TRIAxIAL CELL MAX. Ø 100X200 MM

Technical Specifications:

Max. specimen size: mm Ø 100x200

Max. cell pressure: 1700 kPa

Overall dimensions: Ø 350x595 mm

Weight: 18 kg approx.

##### S306N + S306-10

##### TRIAxIAL CELL MAX. Ø 150X300 MM

Technical Specifications:

Max. specimen size: Ø 150x300 mm

Max. cell pressure: 1700 kPa

Overall dimensions: Ø 350x655 mm

Weight: 19 kg approx.

#### MEASURE OF AXIAL FORCE

##### S337-43N

##### LOAD CELL 25 KN WITH SIGNAL CONDITIONER

Rated output: 2 mV/V nominal

Accuracy: 0.1%

##### S337-41N

##### LOAD CELL 50 KN WITH SIGNAL CONDITIONER

Rated output: 2 mV/V nominal

Accuracy: 0.1%

#### MEASURE OF AXIAL STRAIN

##### S336-23N

##### TRANSDUCER TYPE "A" TRAVEL 25 MM WITH SIGNAL CONDITIONER

Independent linearity: <math><0.3\%</math> (0.3 x 10 mm)

Max. displacement speed: up to 10 m/S



**Note:** For different requirements load cells capacity and transducers stroke or submersible load cells, other capacities are available on request.

#### ACCESSORIES

##### S305-05

Mounting device of the universal coupling pliers mod. S335-15 to fix the displacement transducer/dial gauge to the Triaxial Cell.

##### S335-15

Universal coupling pliers to hold the transducer/dial gauge. It fits all Matest displacement transducers and dial gauges (from dia. 8mm to 20mm).

##### S337-51

Calibration process of one force, strain and pressure device that is combined with the CDAS control and data acquisition system.



S305-05



S305 with accessories

S306N

#### DEAIED WATER SYSTEM

##### S355

##### DE-AIRING TANK 20 LITRES CAPACITY

It produces de-aired water when connected to the vacuum pump. It is a perspex tank with an inlet water valve and an outlet air valve.

Tank capacity: 20 litres.

Dimensions:

320x320x520 mm

Weight:

15 kg approx.



S355

#### ACCESSORIES

##### V205 KIT

Consist of:

##### V205

##### VACUUM PUMP

To produce vacuum up to of 0.1 mbar (see General Catalogue)



##### V205-10 - V205-12

VACUUM REGULATOR It is supplied with vacuum gauge, control valve, suction filter and moisture trap.

##### V230-03

Rubber tube.

Suitable for vacuum, 3 m

##### V205-13

De-oiling filter for vacuum pump

#### MEASURE OF PORE PRESSURE SYSTEM AND VOLUME CHANGE

##### S349N

##### PRESSUREMATIC PVC FOR AUTOMATIC PRESSURE AND VOLUME CONTROL

Technical Specifications:

Output pressure: 3500 kPa

Volume capacity: 250 cc.

See General Catalogue

#### NEEDED ACCESSORIES

**S336-53N** Pressure transducer 2000 kPa with signal conditioner.

**S336-55** De-airing block for pressure transducer

**S349-10** Solenoid valve

#### OPTIONAL ACCESSORIES

**S342-03** 3 ways water distribution panel

## CYCLIC TriaxLab Automated System

STANDARDS: ASTM D7181 | ASTM D2850 | ASTM D3999 | ASTM D4767 | ASTM D5311 | BS 1377:7 | BS 1377:8 | AASHTO T307-9

### MAIN FEATURES

- Automatic execution of static and dynamic triaxial tests.
- Servo feedback controlled precision pressure (Pressurematic) generation system.
- Digital Servo-Pneumatic Control to provide accurate loading wave shapes up to 70 Hz.
- Possibility to upload user-defined wave-shapes (e.g. earthquakes time series) through Replay Editor.
- Fully configurable to suit a large range of testing applications including maximum shear modulus calculation through bender elements option.
- Programmable Dashboard display showing real-time system status charting and test result.



DTS-9 Cyclic TriaxLab Automated System

The Cyclic TriaxLab automated with its innovative features represents the most ideal solution for modern laboratories that need to investigate the effects of vibration and dynamic loading for soil and unbound granular materials.

Typical applications include: civil engineering including seismic and blasting analysis; environmental engineering; construction and architectural design and advanced research on soils.

Based on the 4 axis control and 16 channel control and Data Acquisition CDAS2, Matest Cyclic TriaxLab has provision for:

- Vertical load tension/compression up to 9 kN
- Vertical displacement up to 50 mm
- Cell pressure up to 2000 KPa
- Back pressure up to 2000 KPa

The Cyclic TriaxLab automated system is subdivided into 3 major groups similarly to the TriaxLab Automated System:

- **Fully digital controlled load frame** and fit for purpose Triaxial cell with accessories
- **Control system** based on the CDAS2
- **Data Acquisition System** comprising:
  - 1 submersible load cell for axial force
  - 3 pressure transducers for cell pressure, back pressure and pore pressure
  - 2 Pressurematic for pressure/volume change

To suit the specific customer's requirements the Cyclic TriaxLab Automated System basic configuration can be modified by adding or removing the hardware elements which are controlled and monitored under a closed-loop integrated system with the CDAS2 and TestLab Software. Pre-programmed "Method files" offer the operator the unique opportunity to run a range of tests without the need for specific computer programming. The possibility to customize the Method files is also given to the operator granting ultimate flexibility and versatility.

## CYCLIC TriaxLab Automated System ORDERING INFO:

### HARDWARE - SOFTWARE

#### B220-04 KIT DTS9 WITH MANUAL CROSSHEAD

The machine includes:

##### B220-14

20 kN load frame with manual crosshead  
9 kN servo-pneumatic actuator with its LVDT,  
50mm stroke, 70 Hz frequency.

**Power supply:** 90-264V 50-60Hz 1ph 240W

**Dimensions:** 1262(h)x400(d)x470(w)

**Weight:** 80 kg load frame

##### S303N

16 Channel Control and Data Acquisition  
System (CDAS2) and TestLab software.

For technical specifications, see p. 22

##### B270-12

Air reservoir assembly with membrane dryer.  
It requires pressurized air, minimum 7 bar  
(not included)

As alternative:

#### B220-05 KIT DTS-16 WITH MANUAL CROSSHEAD

The machine includes:

##### B220-15

20 kN load frame with manual crosshead 16  
kN Servo-Pneumatic actuator with its LVDT  
30 mm stroke, 70 Hz frequency.

Power supply, dimensions and weight are the  
same as B220-04 KIT.

**S303N** 16-ch CDAS2 and TestLab  
software.

**B270-12** Air reservoir assembly with  
membrane dryer.

##### S307

#### TRIAxIAL CELL MAX Ø 150X300 MM

Technical specifications:

- Max specimen mm Ø 150x300
- Max cell pressure 2200 kPa
- Overall dimensions mm Ø 338x648
- Weight 40 kg approx.

##### S306N+S306-10

#### TRIAxIAL CELL MAX Ø 150X300 MM

Technical specifications:

Max. specimen size: Ø 150x300 mm  
Max. cell pressure: 1700 kPa  
Overall dimensions: Ø 350x655 mm  
Weight: 19 kg approx.

### MEASURE OF AXIAL FORCE

#### S337-06N

#### SUBMERSIBLE LOAD CELL 10 KN WITH SIGNAL CONDITIONER

- Rated output 2 mV/V nominal
- Accuracy 0.1%

 **Note:** For different requirements load  
cells capacity and transducers stroke or sub-  
mersible load cells, see General Catalogue  
Other capacities are available on request.

### ACCESSORIES FOR TRIAXIAL CELL

**S337-23** Loading ram for the submersible  
load cell (only for S307)

**S337-22** Loading ram for the submersible  
load cell (only for S306N)

**S307-05** Transducers holder ring

**S307-10** Vacuum generator

**S307-19** Vacuum adaptor

**S307-11** Alignment coupler assembly

**S307-12** Spherical exclusion

**S307-13** Base pedestal spacer

**S307-14** Piston stop device

### OPTIONAL ACCESSORIES

BENDER ELEMENTS KIT for the evaluation of  
the stiffness of a soil starting from the meas-  
urement of the maximum shear modulus  
(G<sub>max</sub>). The Kit includes:

**S307-08** Picoscope

**S307-07** T-4001 waveforms transformer

**S307-03** Kit of upper and lower bender  
holders

**S307-22** | **32** | **42** | **52**  
Base pedestal for bender element  
Ø 38 | 50 | 70 | 100 mm

**S307-23** | **33** | **43** | **53**  
Top platen for bender element  
Ø 38 | 50 | 70 | 100 mm

**S307-24** | **34** | **44** | **54**  
Pair of porous disc  
Ø 38 | 50 | 70 | 100 mm

### DEAIRED WATER SYSTEM

#### S355

#### DE-AIRING TANK 20 LITRES CAPACITY

It produces de-aired water when connected  
to the vacuum pump. It is a Perspex tank with  
an inlet water valve and an outlet air valve.  
Tank capacity: 20 litres.

**Dimensions:** 320x320x520 mm

**Weight:** 15 kg approx.

### ACCESSORIES

#### V205 KIT

Consist of:

##### V205

#### VACUUM PUMP

To produce vacuum  
up to of 0.1 mbar  
(see General Catalogue)



##### V205-10 - V205-12

VACUUM REGULATOR It is supplied with  
vacuum gauge, control valve, suction filter  
and moisture trap.

**V230-03** Rubber tube.

Suitable for vacuum, 3 m

**V205-13** De-oiling filter for vacuum pump

 **Note:** Other models of vacuum pumps  
described on the General Catalogue

### MEASURE OF PORE PRESSURE SYSTEM AND VOLUME CHANGE

#### S349N

#### PRESSUREMATIC PVC FOR AUTOMATIC PRESSURE AND VOLUME CONTROL

Output pressure: 3500 kPa

Volume capacity: 250 cc

For Technical Specifications, see General  
Catalogue

### NEEDED ACCESSORIES

**S336-53N** Pressure transducer 2000 kPa  
with signal conditioner.

**S336-55** De-airing block for pressure  
transducer

**S349-10** Solenoid valve

**B204-16** Air compressor 11 bar - 500 litres

**S332-08** Hose and fittings designed for  
a more reactive response of the  
dynamic triaxial system.

### OPTIONAL ACCESSORIES

**S342-03** 3 ways water distribution panel



**PAVETEST IS A DIVISION  
OF MATEST**  
COMMITTED TO  
DEVELOPING  
INNOVATIVE DYNAMIC  
TESTING SYSTEMS.

**MATEST S.p.A.**  
Via delle Industrie, 25  
24048 Treviolo (BG) Italy  
Tel. +39 035 2055011  
[www.matest.com](http://www.matest.com)

[www.pavetest.com](http://www.pavetest.com)

